

RU ИНСТРУКЦИЯ ПО СБОРКЕ
EN ASSEMBLY MANUAL

RU Набор мебели для жилой комнаты "Quartz" QZ-01
EN Living room furniture set "Quartz" QZ-01

INTERLINE
furniture production

RU Шкаф комбинированный "QZ-ШК2"
EN Combined wardrobe "QZ-SHK2"

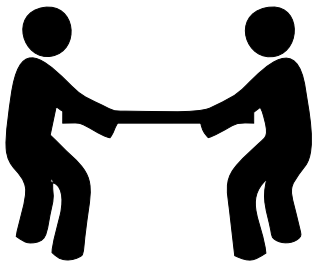
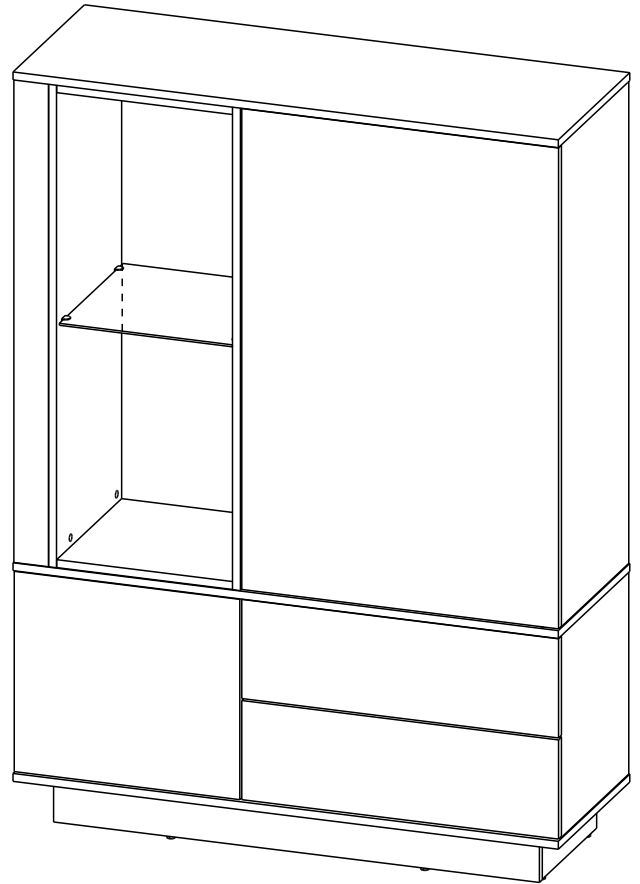
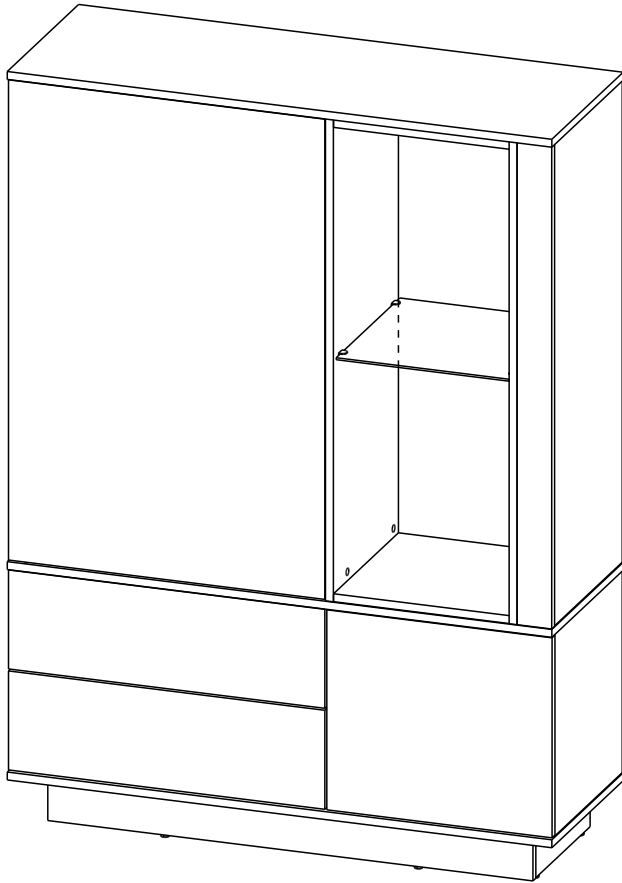

150 min

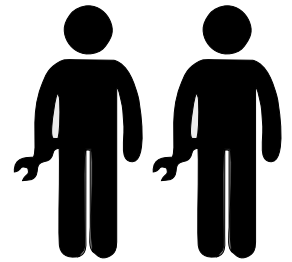

1531x1100x396 mm

RU Необходимый инструмент
EN Required tools

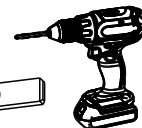
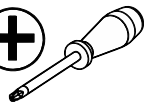

1x



1x

ООО «Центр мебели Интерлиния»
Республика Беларусь 224025
г. Брест ул. Лейтенанта Рябцева 39
тел.: +375 162 95-90-90
тел./факс: +375162 29-88-94
e-mail: info@interline.by
www.interline.by



RU Узнайте больше!
EN Find out more!

LLC "Furniture Center Interline"
Republic of Belarus 224025
Brest st. Lieutenant Ryabtseva 39
tel.: + 375 162 95-90-90
tel./fax: +375162 29-88-94
e-mail: info@interline.by
www.interline.by

RU Шкаф комбинированный "QZ-ШК2"

EN Combined wardrobe "QZ-SHK2"

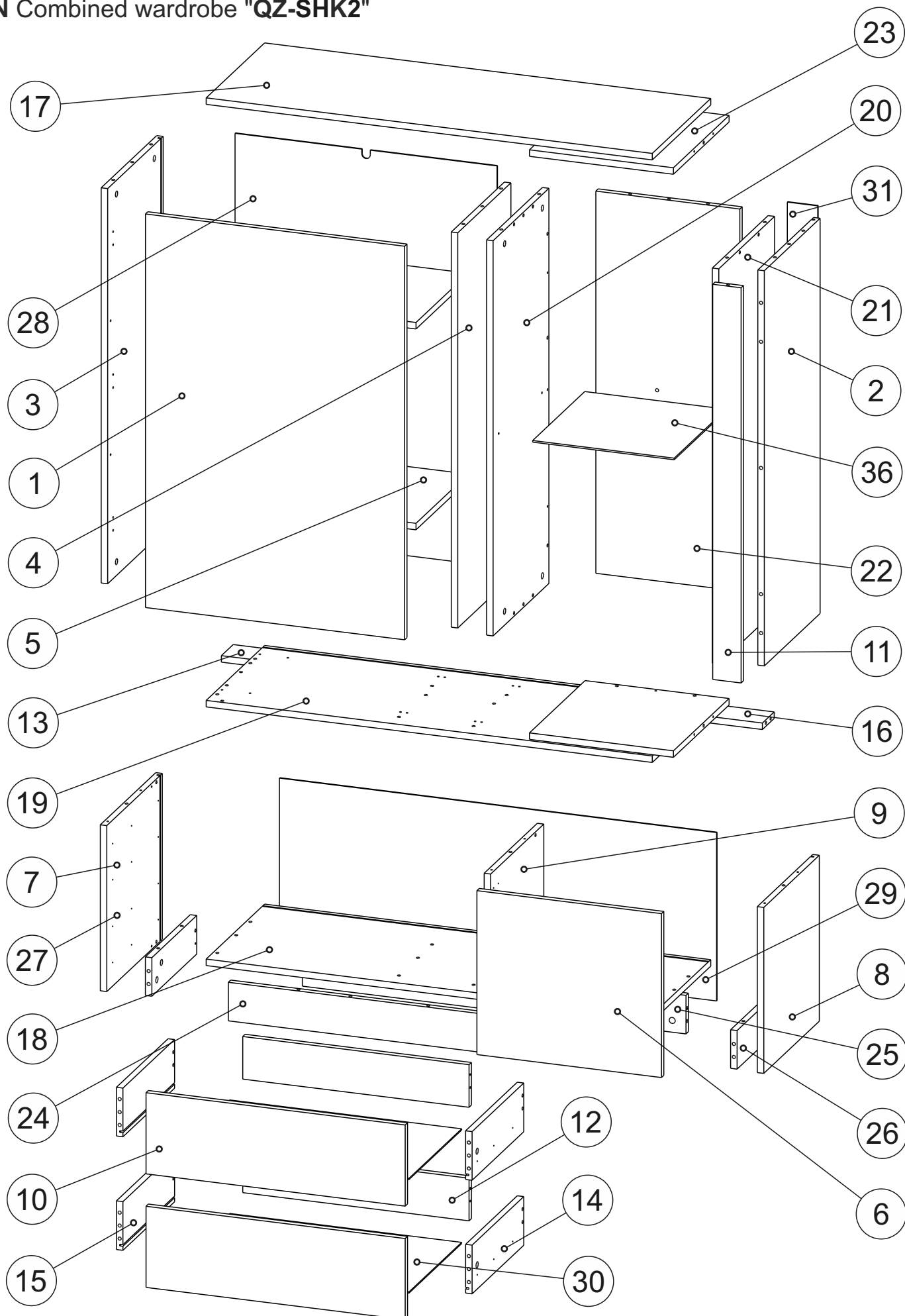

RU Пачка
EN Paket

1/3

- 2
- 3
- 4
- 17
- 18
- 19
- 20
- 21
- 36

2/3

- 1
- 5 **2x**
- 11
- 12 **2x**
- 13
- 14 **2x**
- 15 **2x**
- 16
- 22
- 23 **2x**
- 24
- 25
- 26
- 27
- 28
- 30 **2x**
- 31

3/3

- 6
- 7
- 8
- 9
- 10 **2x**
- 29

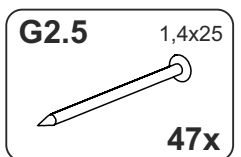
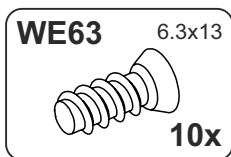
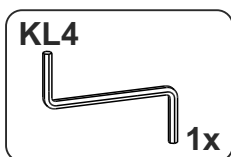
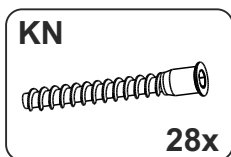
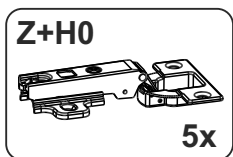
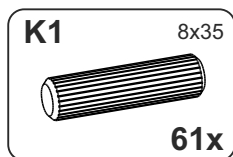
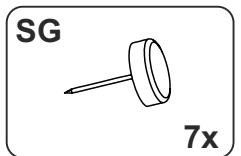
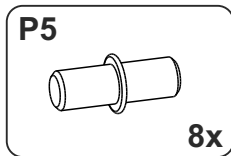
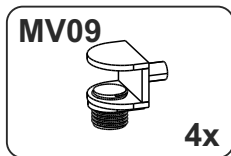
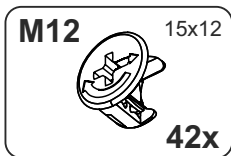
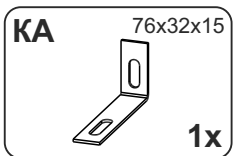
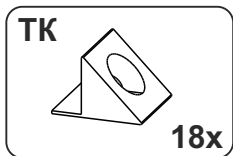
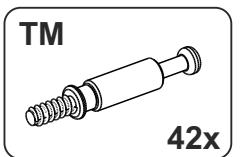
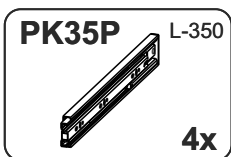
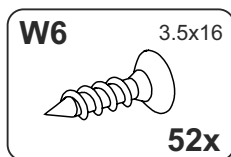
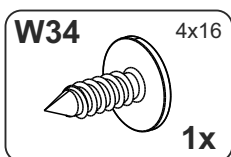
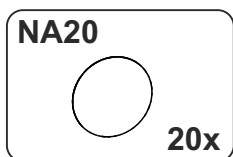
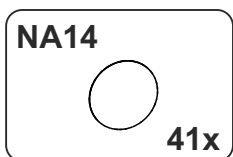
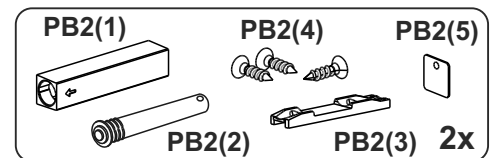

RU Пожалуйста проверьте комплектацию фурнитуры перед сборкой. EN Please check the completeness of the fittings before assembly.



Wycinek dowolny

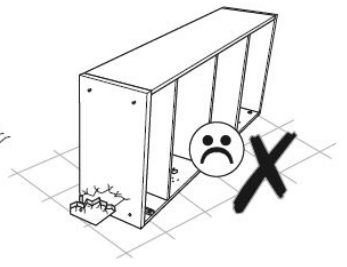
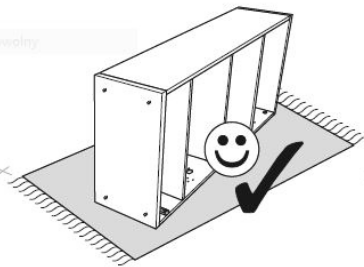
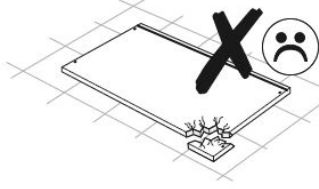
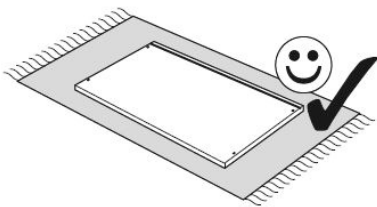

1 **RU** Потребуется для сборки:
EN Required for assembly:

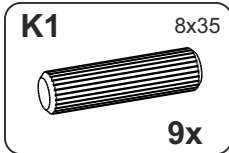
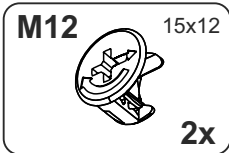
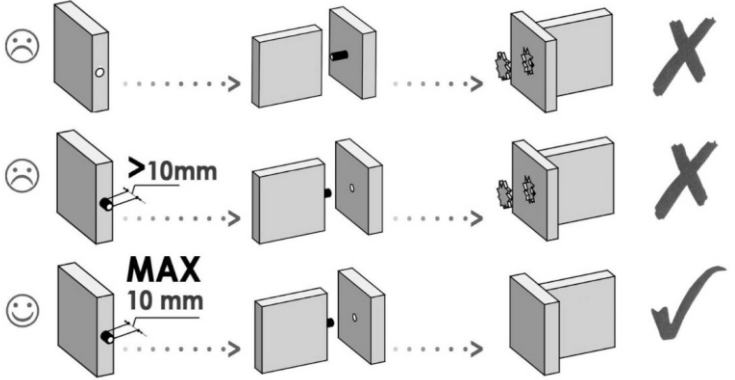

2

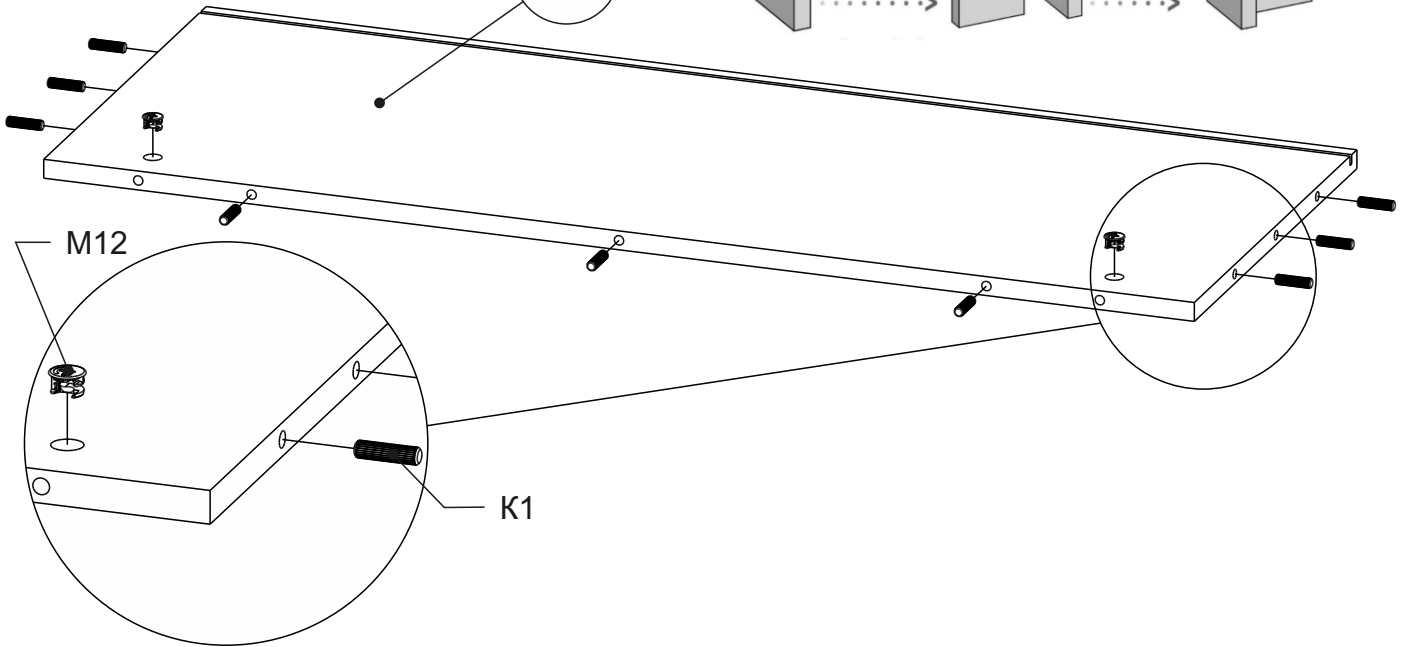

2 **RU** Потребуется для сборки:
EN Required for assembly:

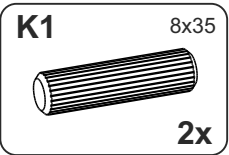
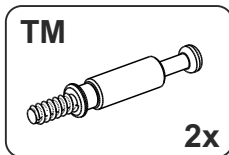
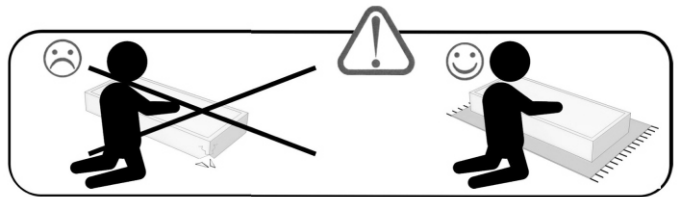

11

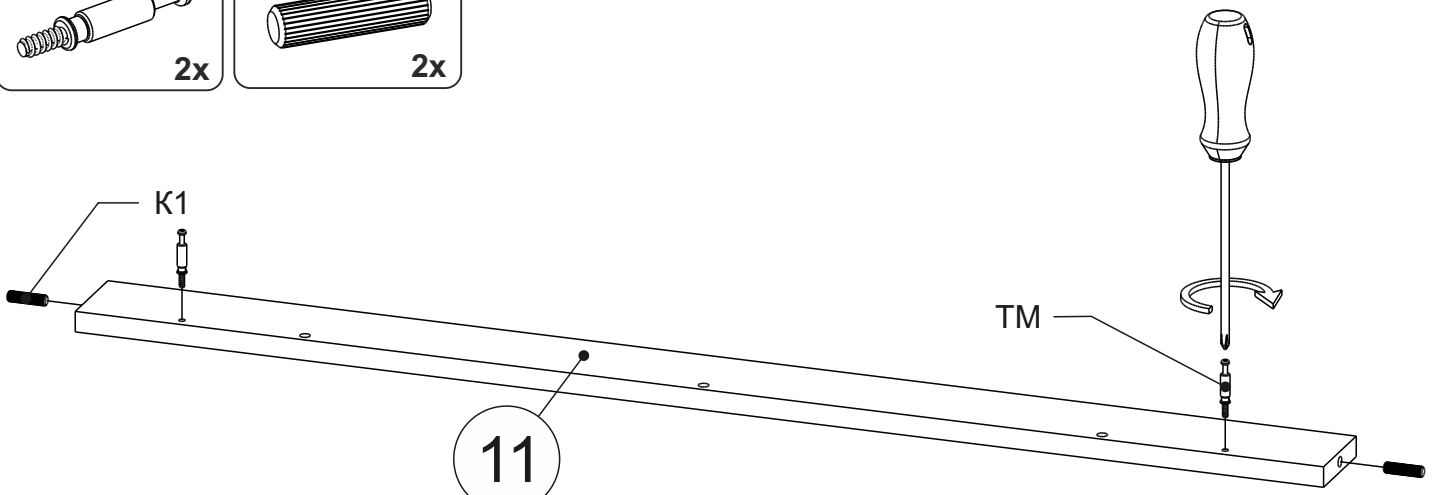

3 **RU** Потребуется для сборки:
EN Required for assembly:

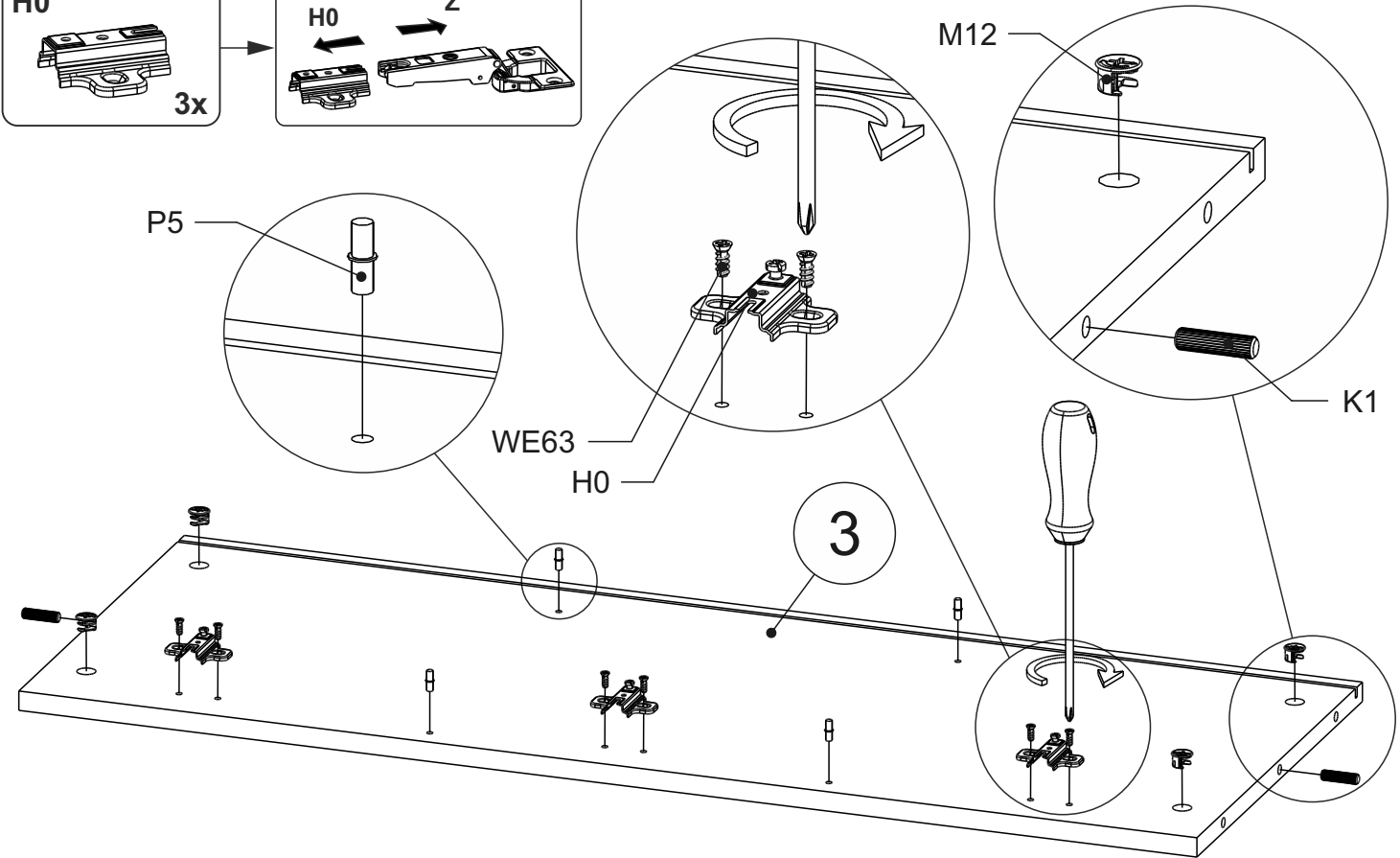
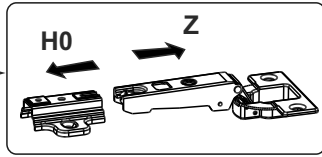
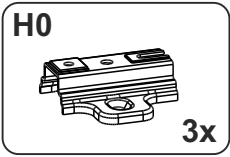
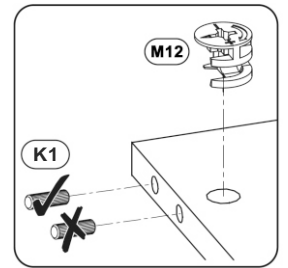
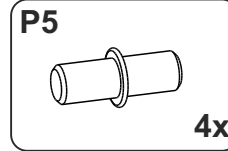
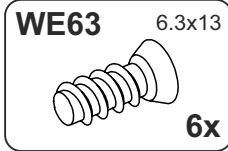
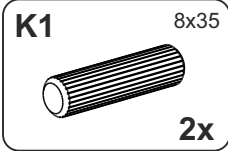
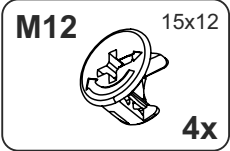

4 **RU** Потребуется для сборки:
EN Required for assembly:

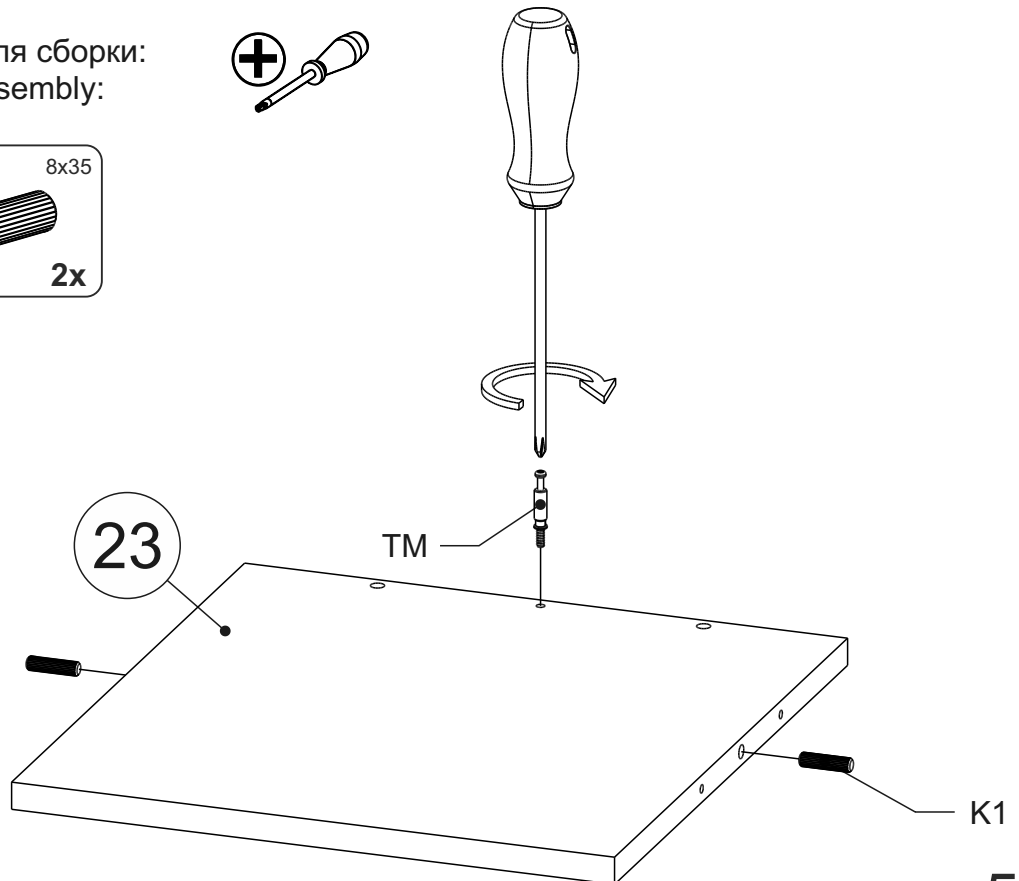
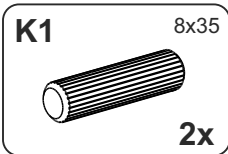
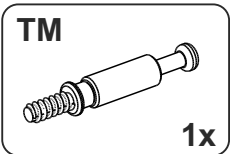

5

RU Потребуется для сборки:
EN Required for assembly:

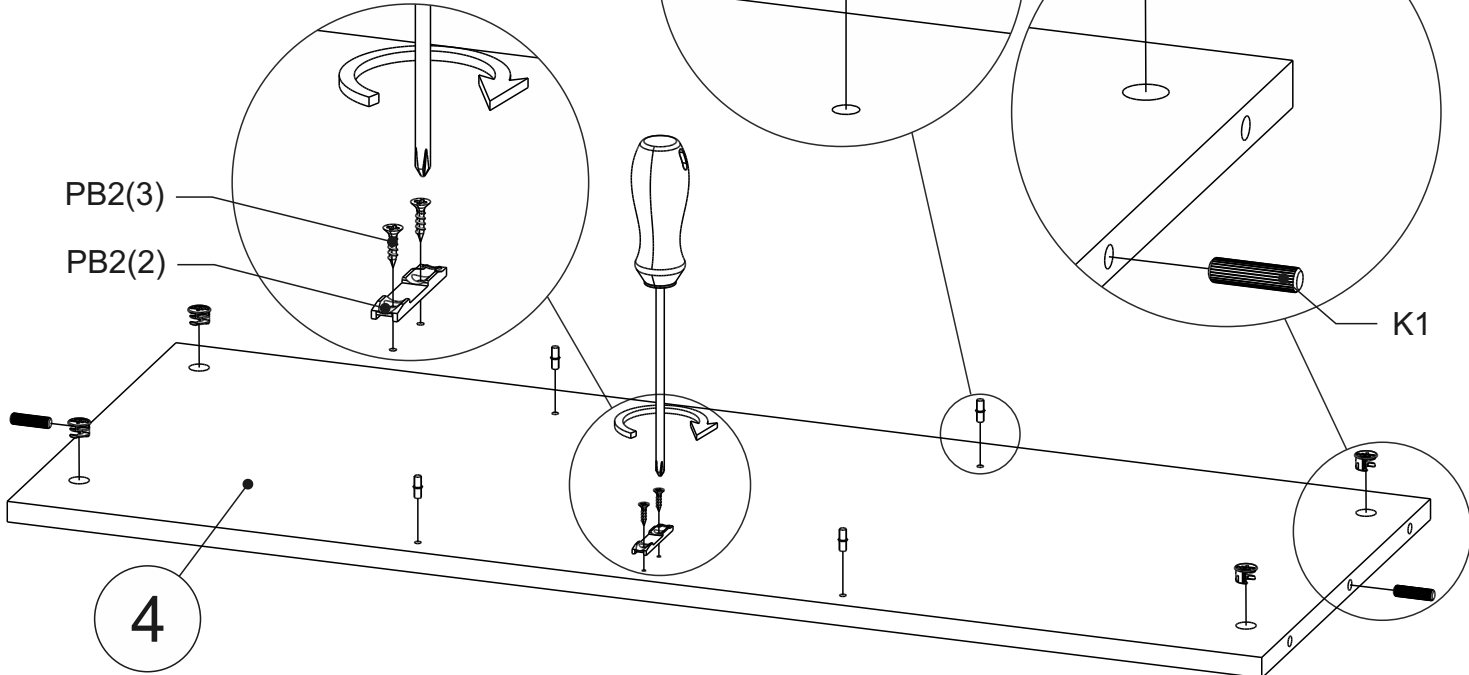
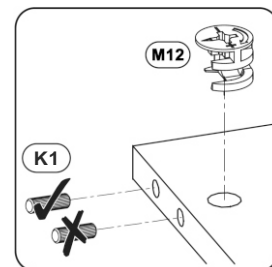
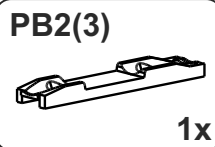
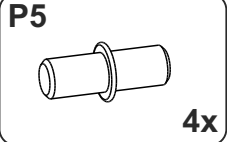
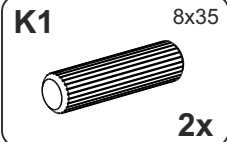
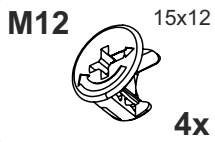

6

RU Потребуется для сборки:
EN Required for assembly:

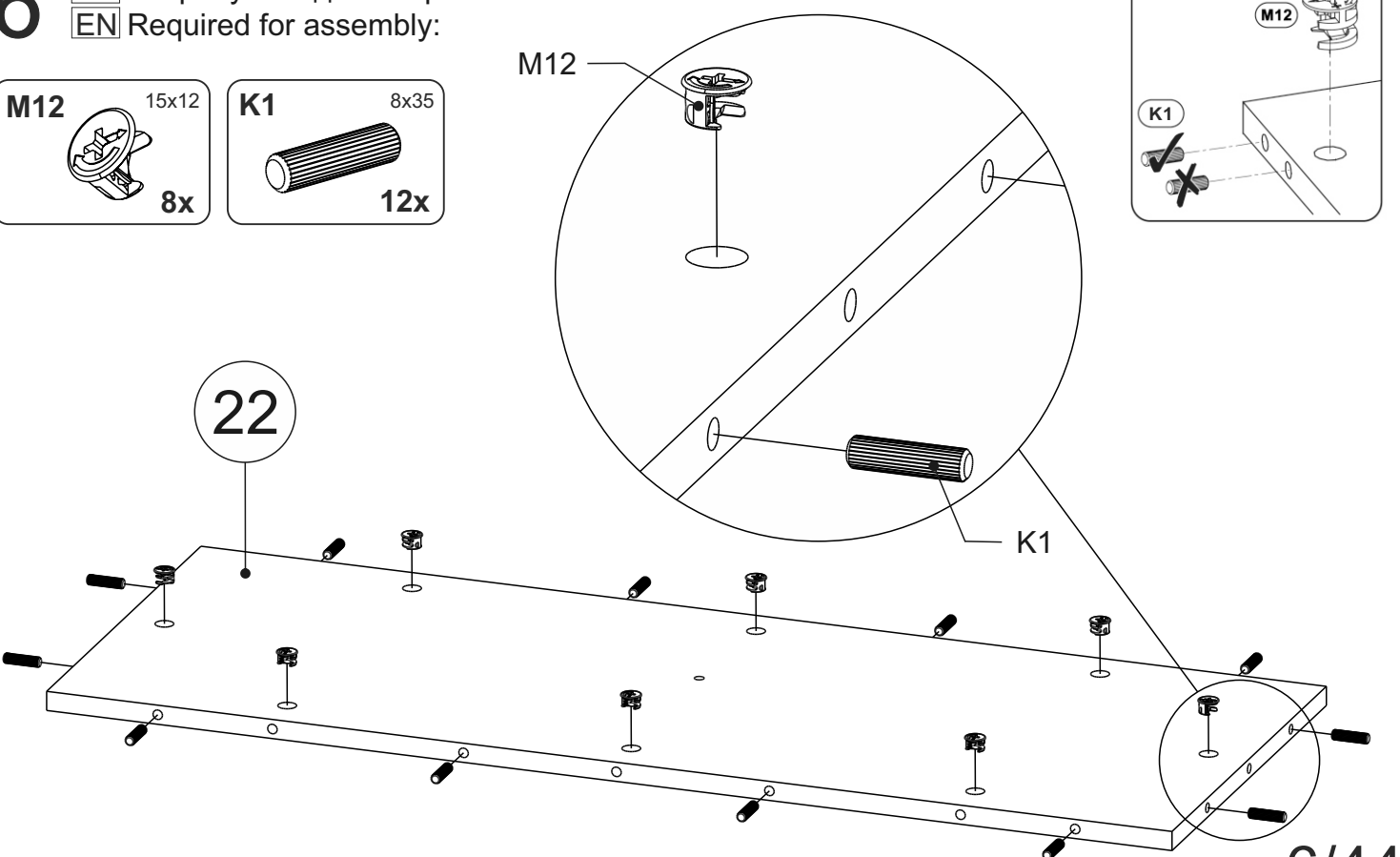
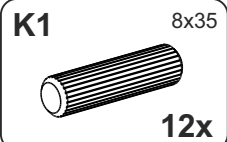
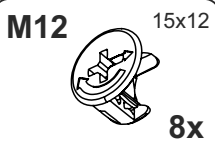

7

RU Потребуется для сборки:
EN Required for assembly:

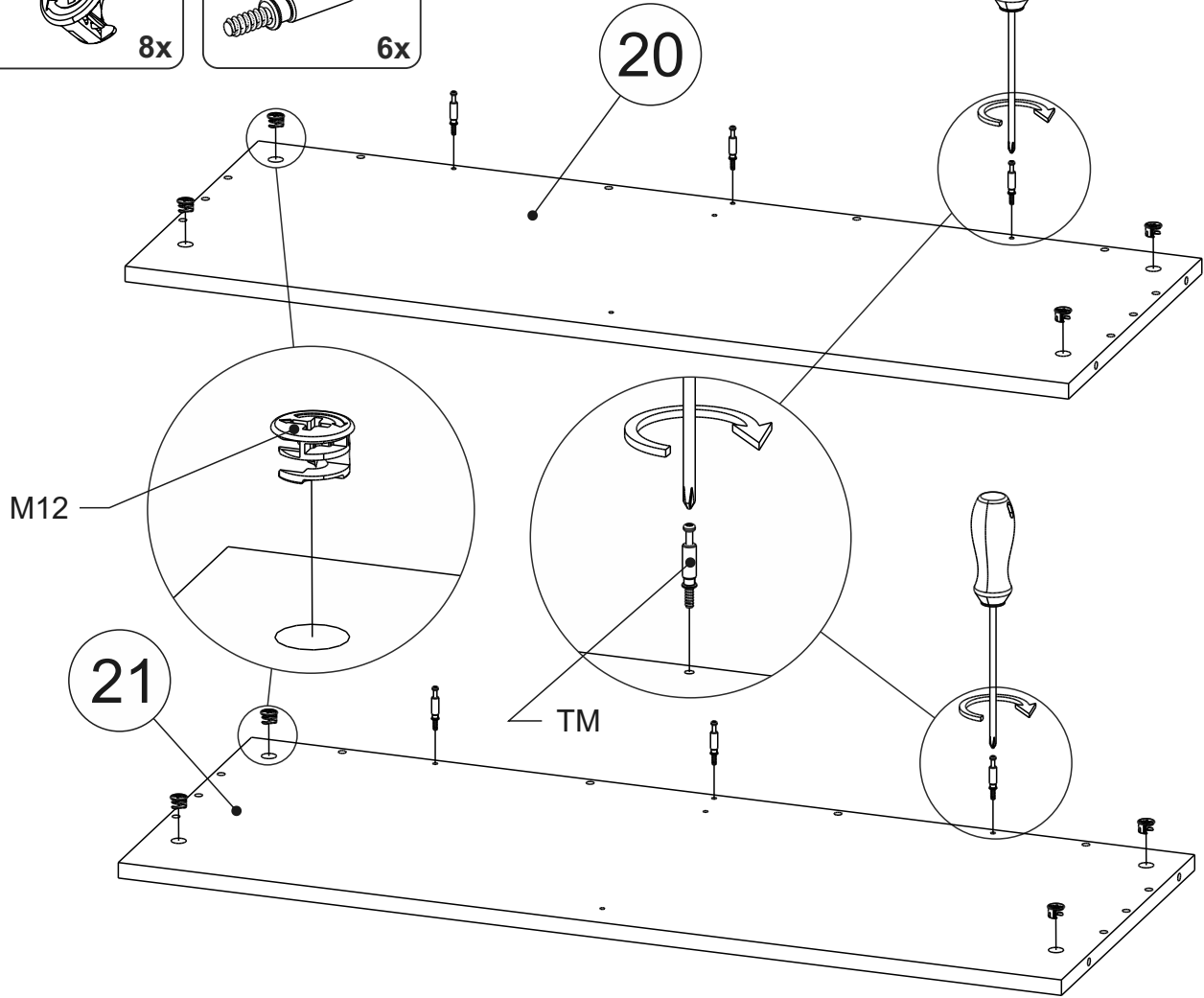
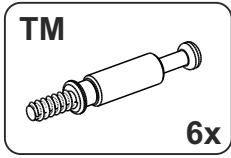
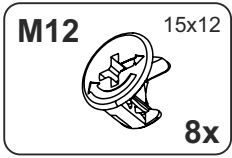

8

RU Потребуется для сборки:
EN Required for assembly:

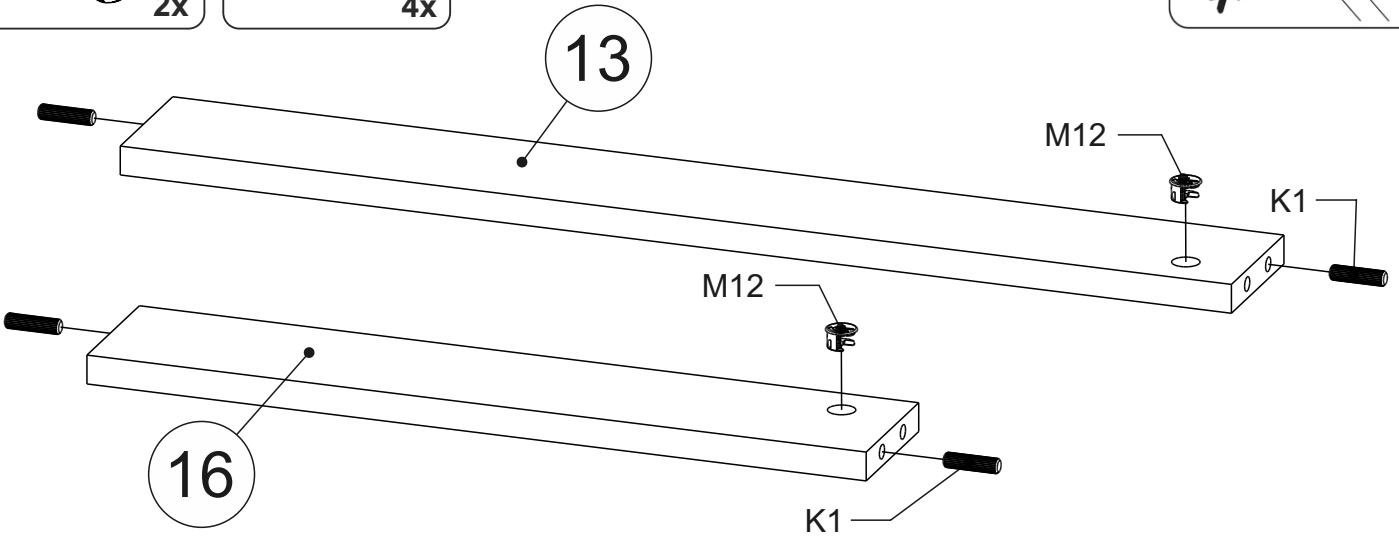
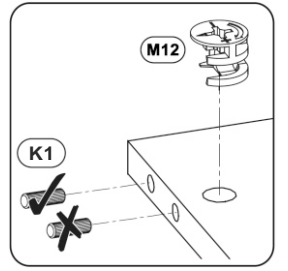
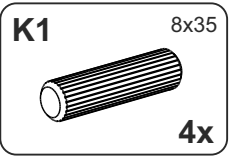
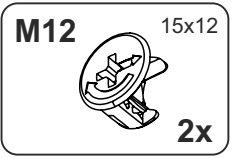

9

RU Потребуется для сборки:
 EN Required for assembly:

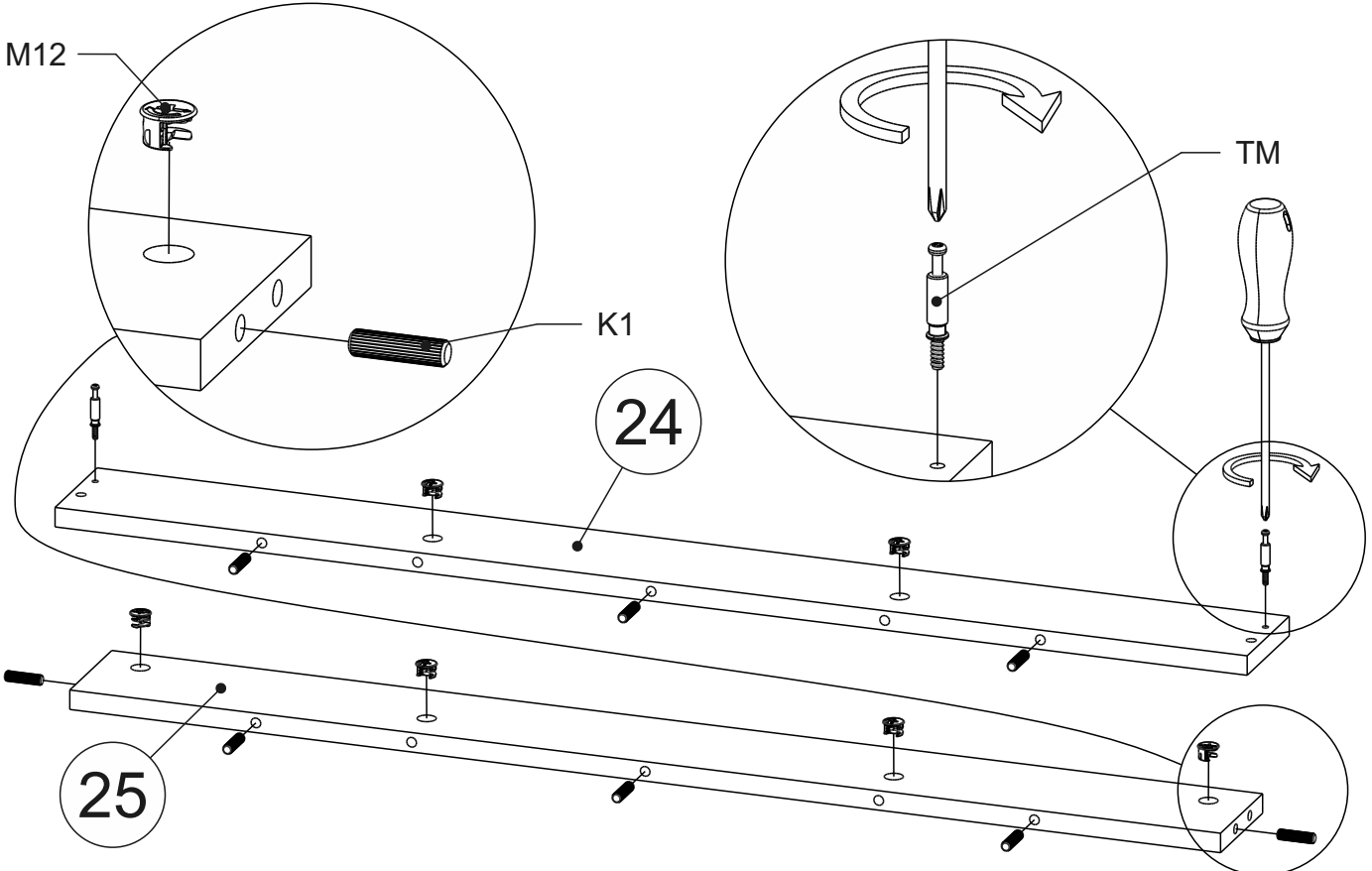
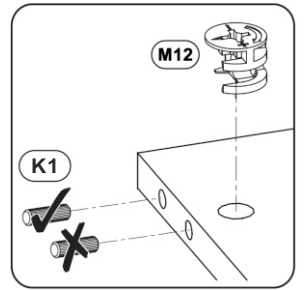
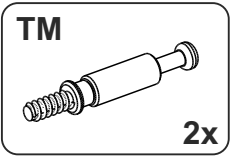
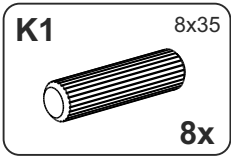
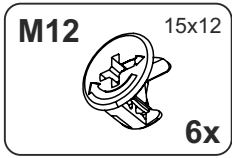

10

RU Потребуется для сборки:
 EN Required for assembly:

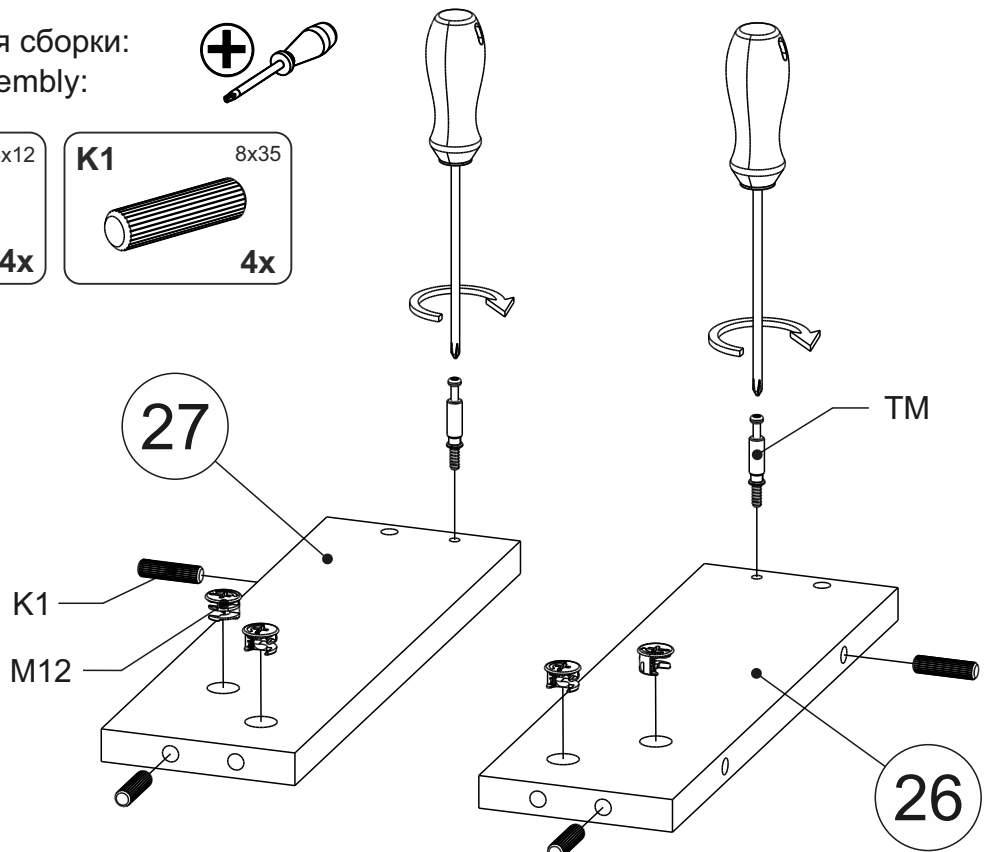
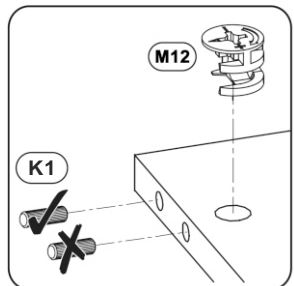
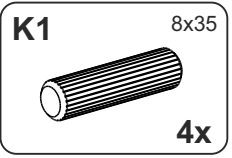
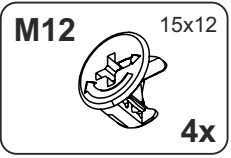
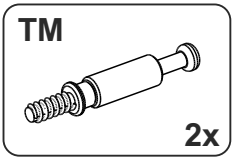

11 RU Потребуется для сборки: EN Required for assembly:

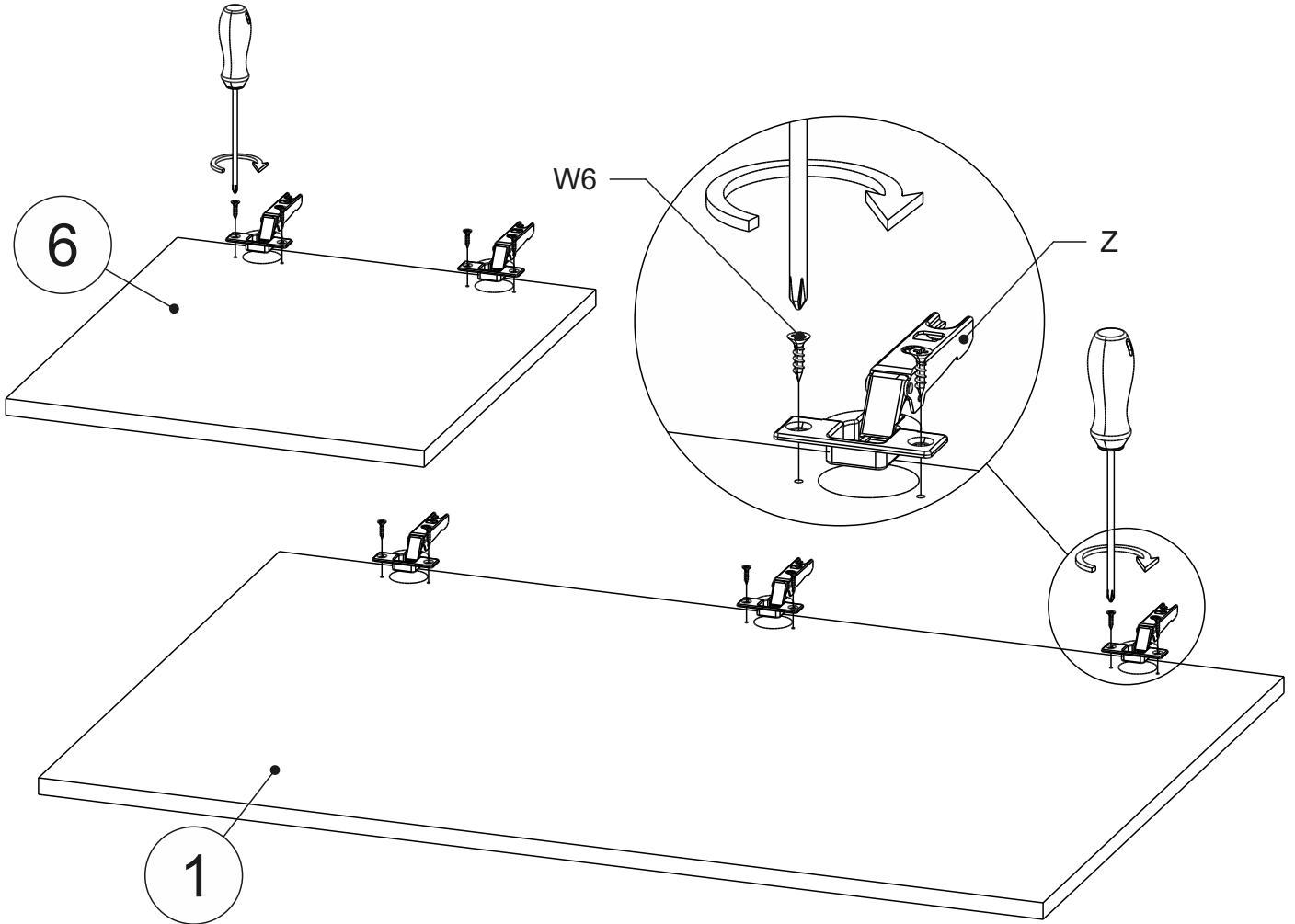
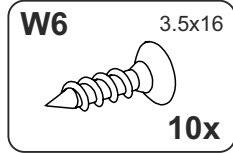
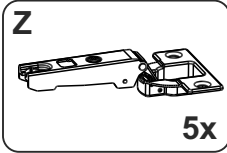
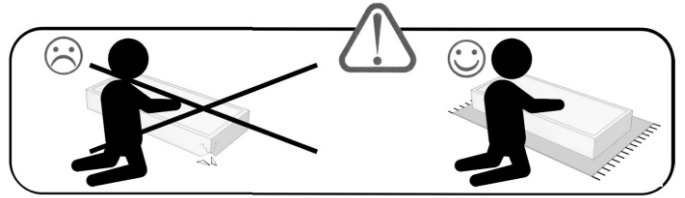
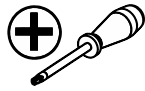

12 RU Потребуется для сборки: EN Required for assembly:

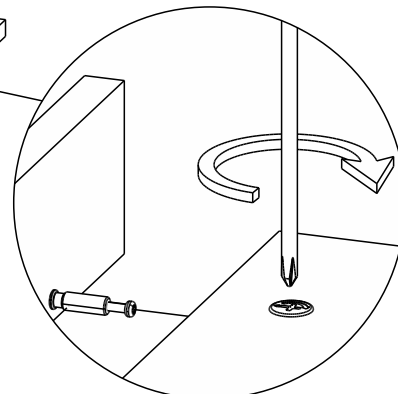
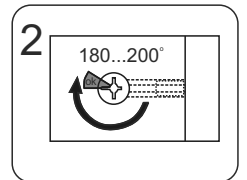
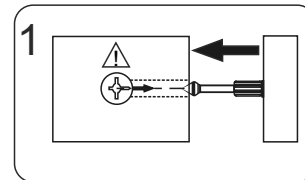
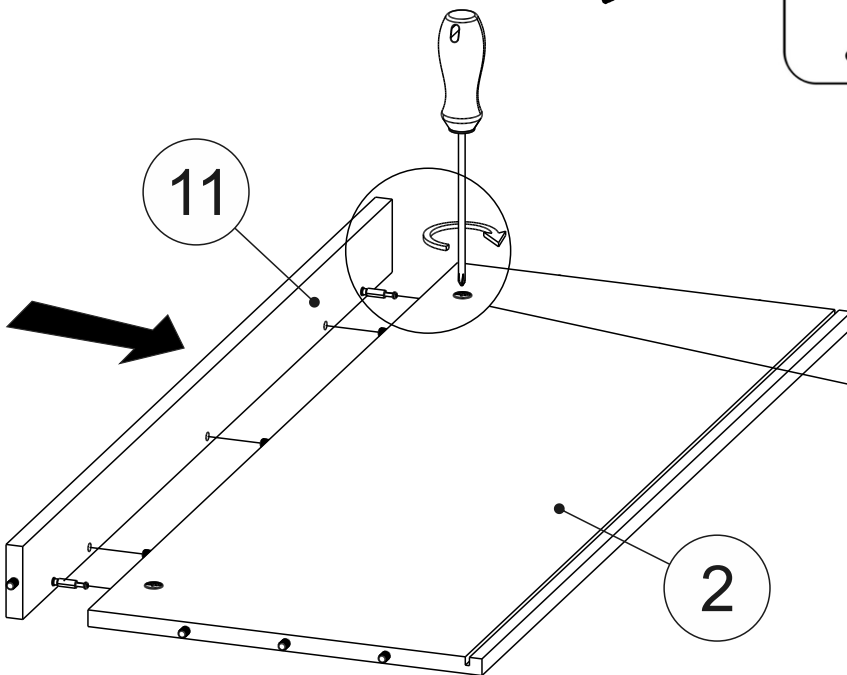
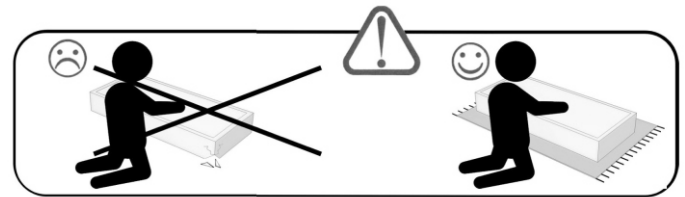

13 **RU** Потребуется для сборки:
EN Required for assembly:

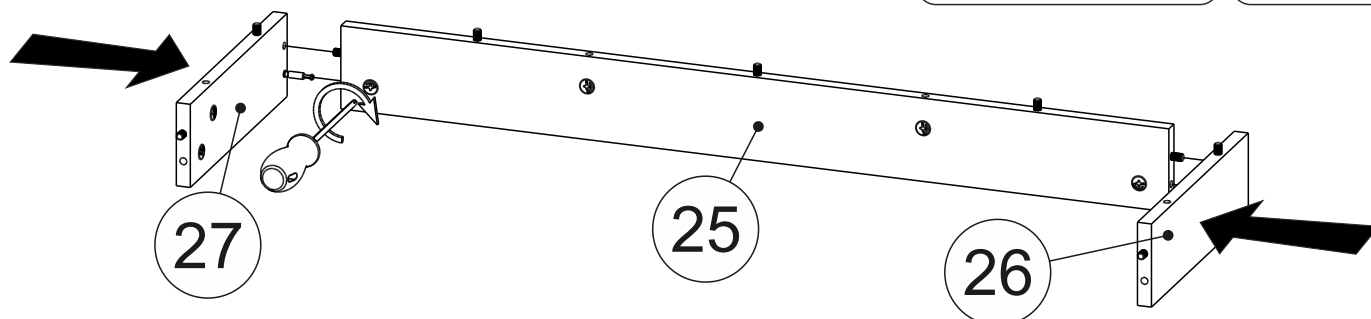
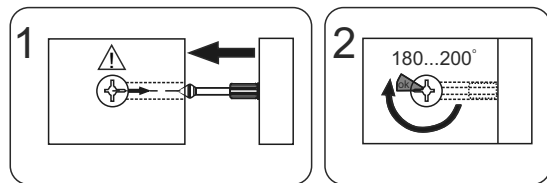
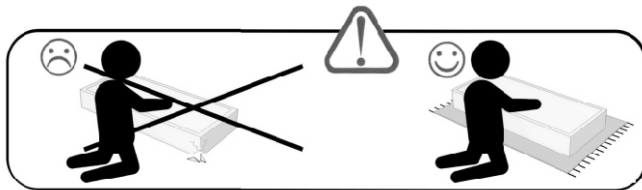

14 **RU** Потребуется для сборки:
EN Required for assembly:

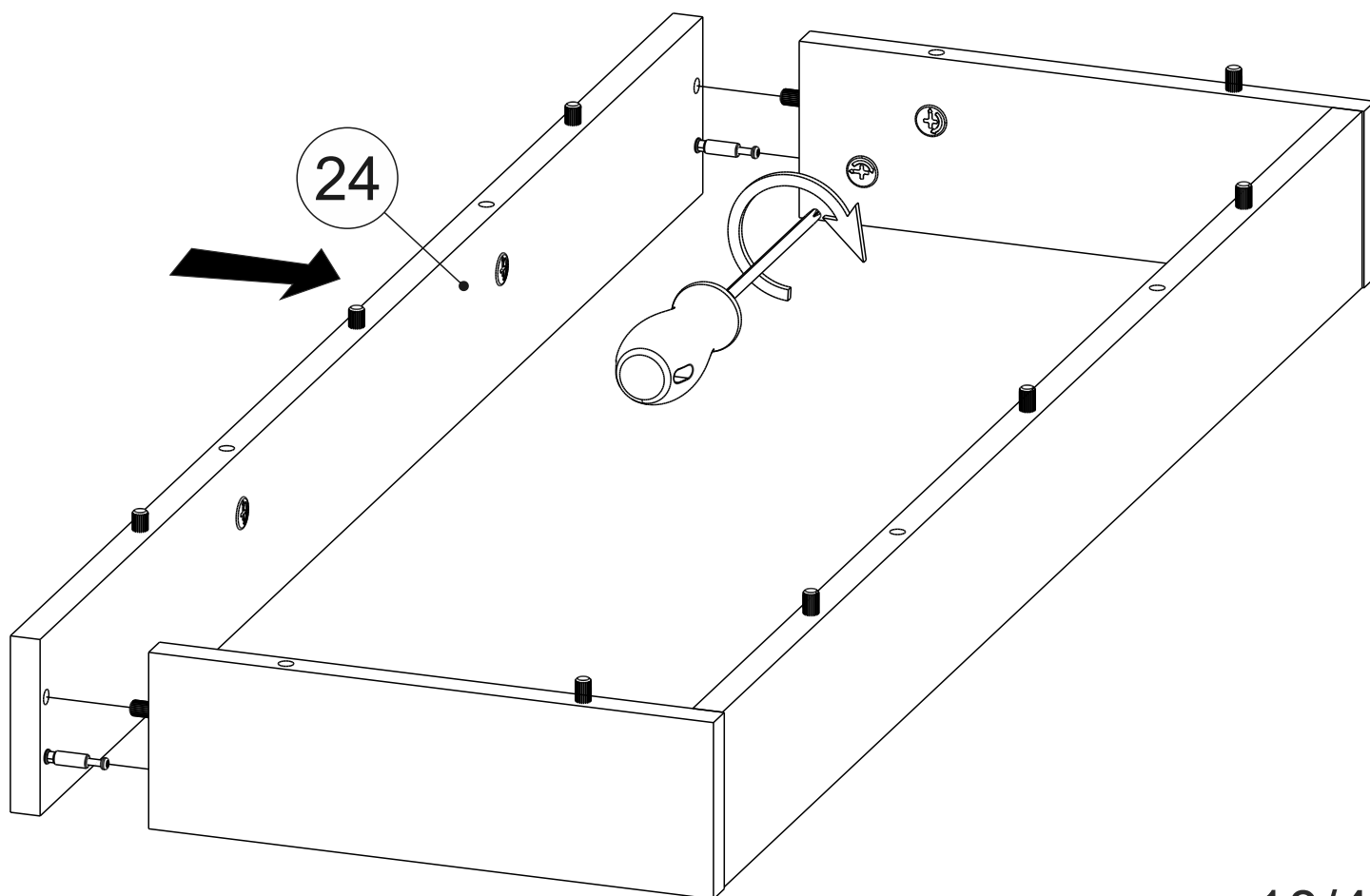
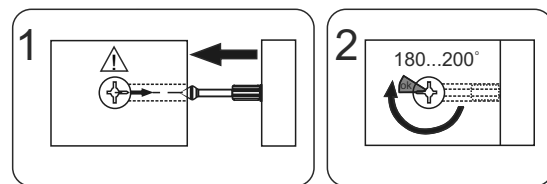
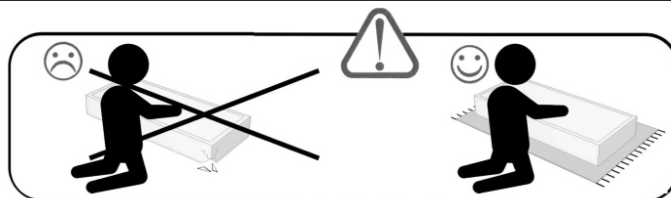

15 RU Потребуется для сборки:
EN Required for assembly:

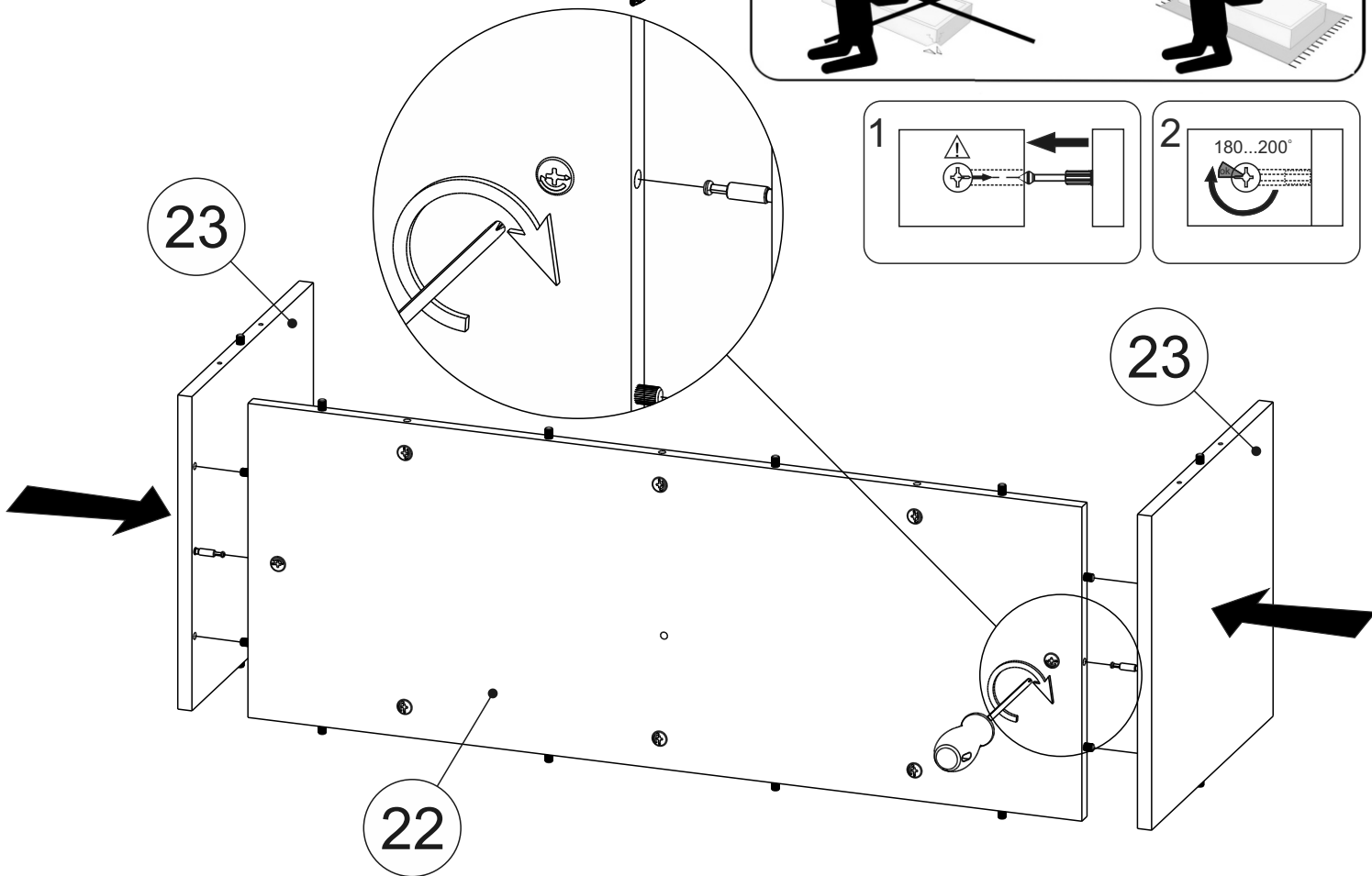
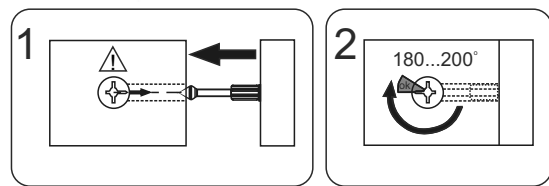
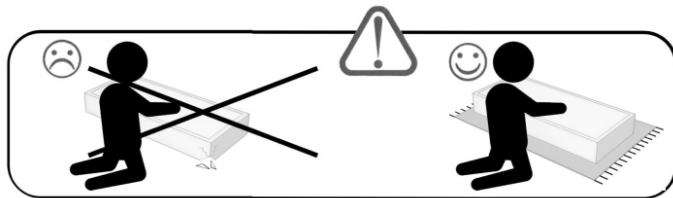

16 RU Потребуется для сборки:
EN Required for assembly:

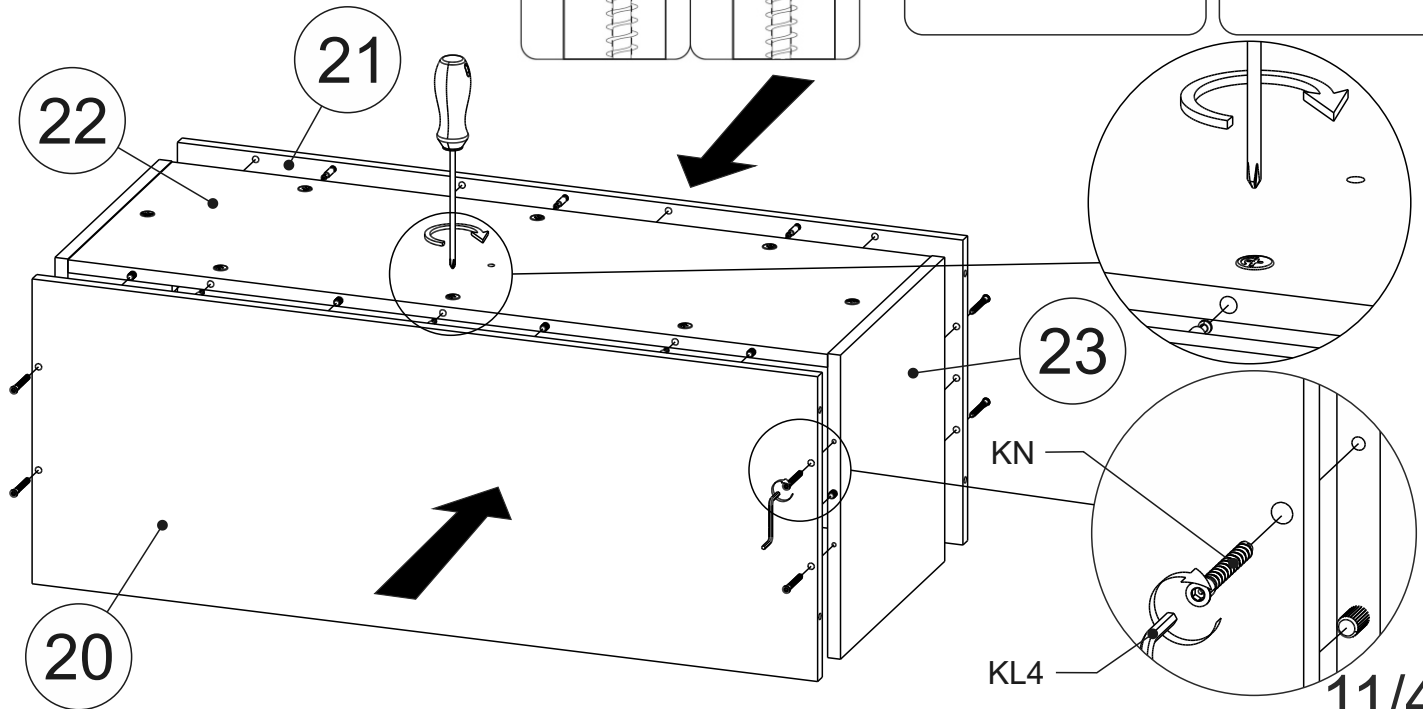
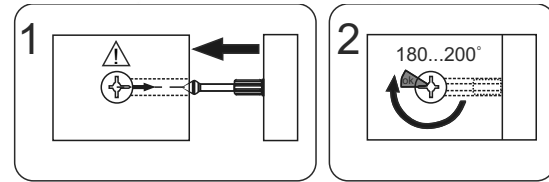
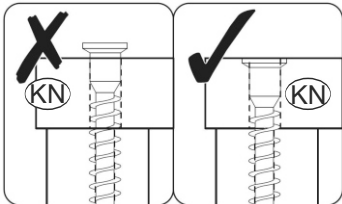
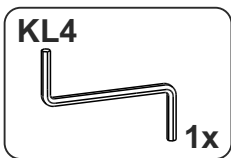
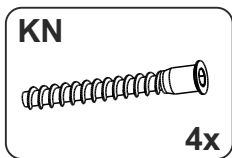
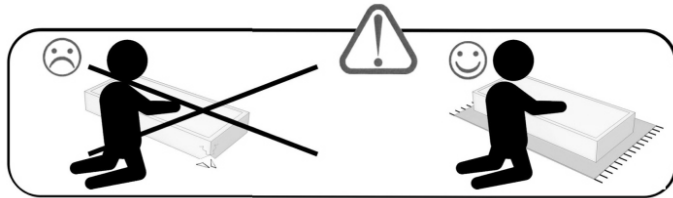

17

RU Потребуется для сборки:
EN Required for assembly:

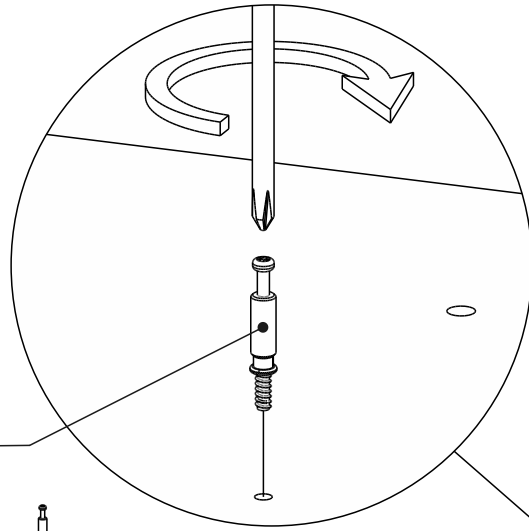
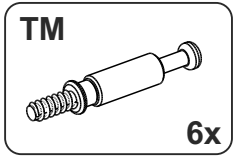
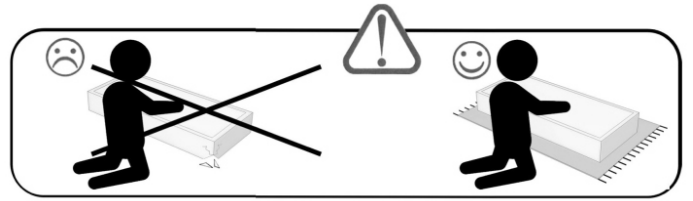

TM

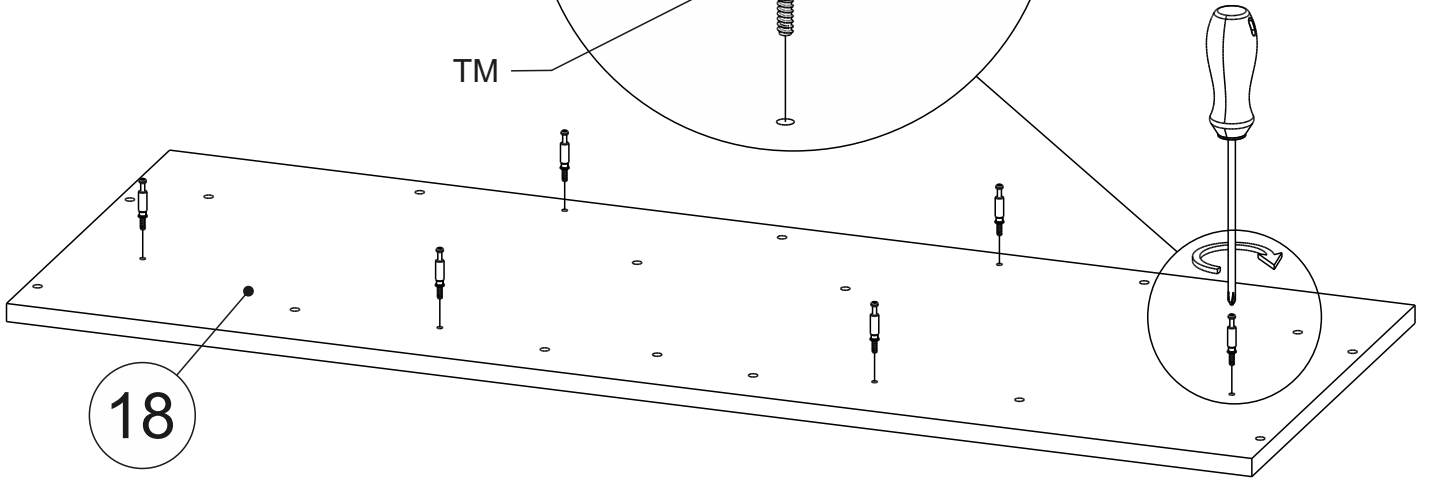

18

18

RU Потребуется для сборки:
EN Required for assembly:

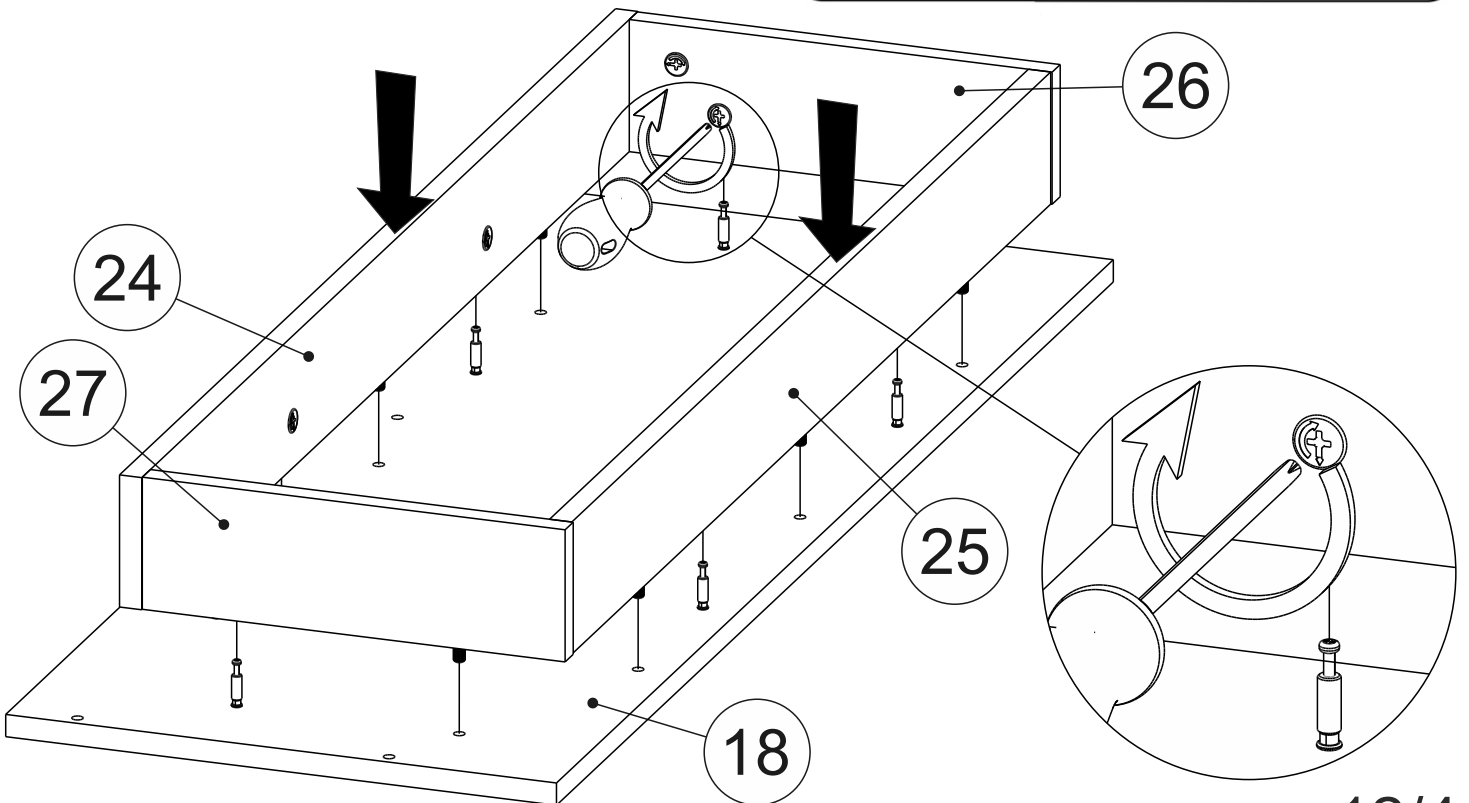
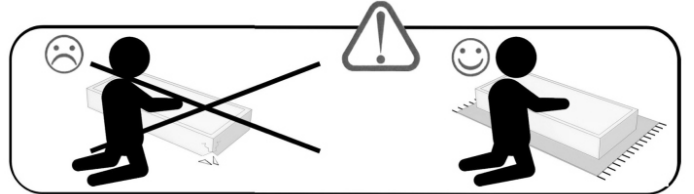

19

RU Потребуется для сборки: 

EN Required for assembly:

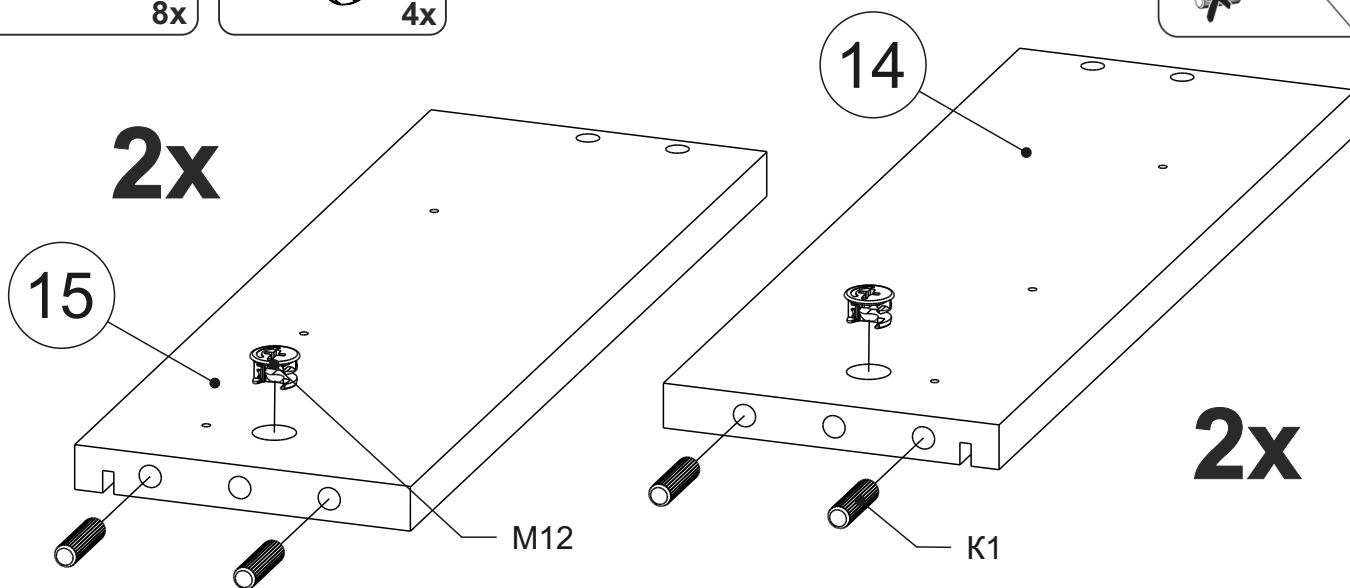
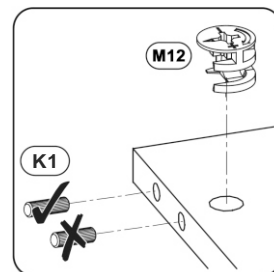
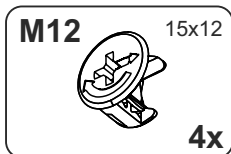
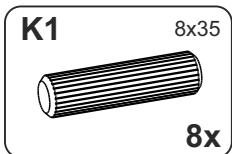

20

RU Потребуется для сборки:

EN Required for assembly:

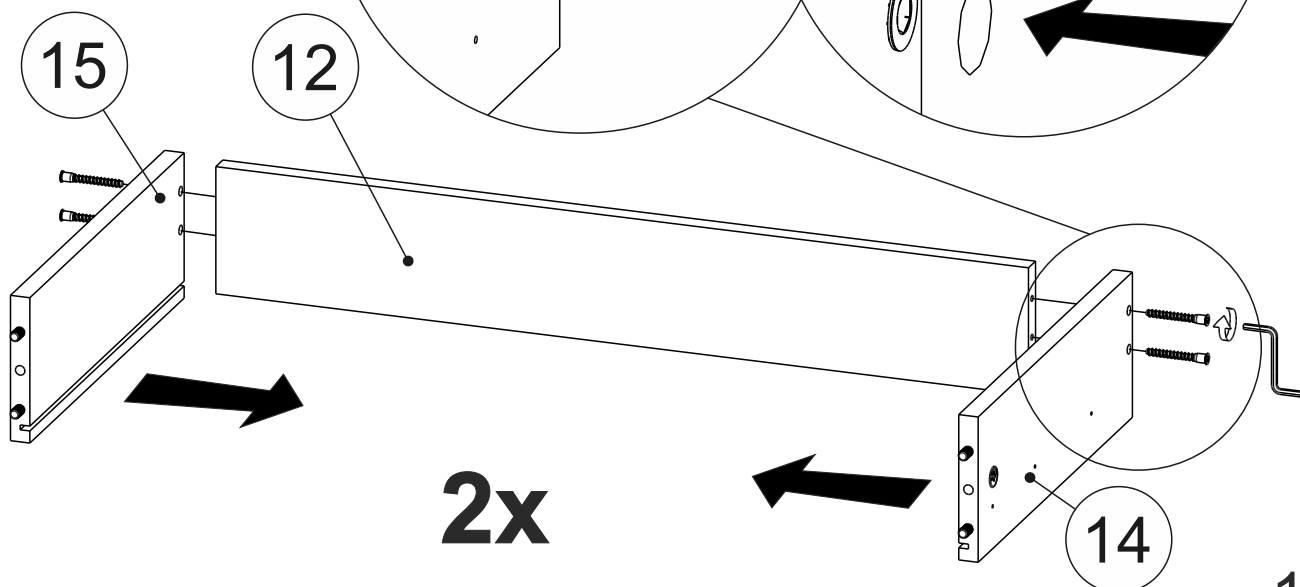
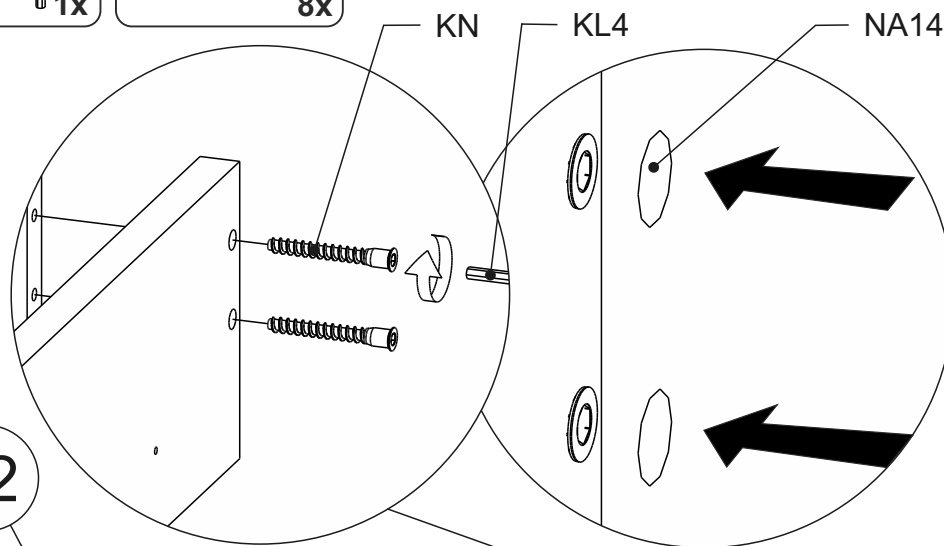
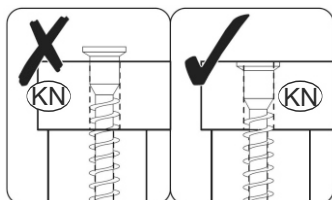
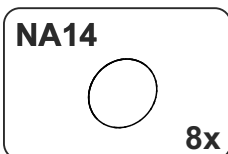
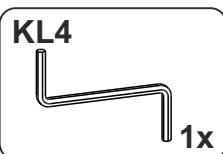
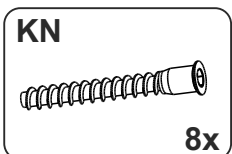
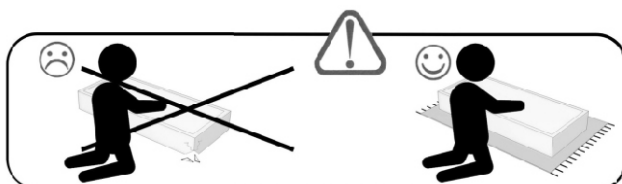

Variant **A**



15-26

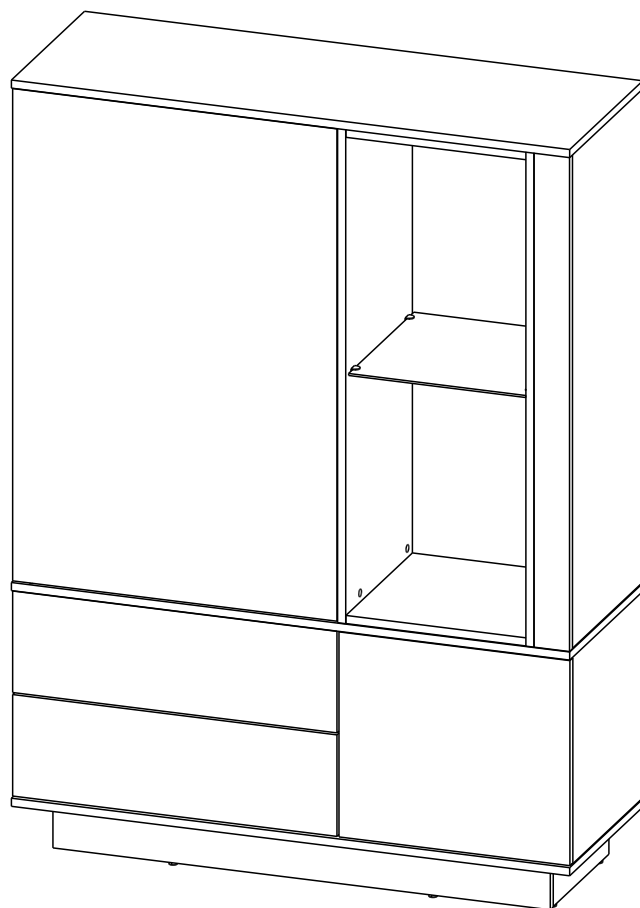

Variant **B**



27-38

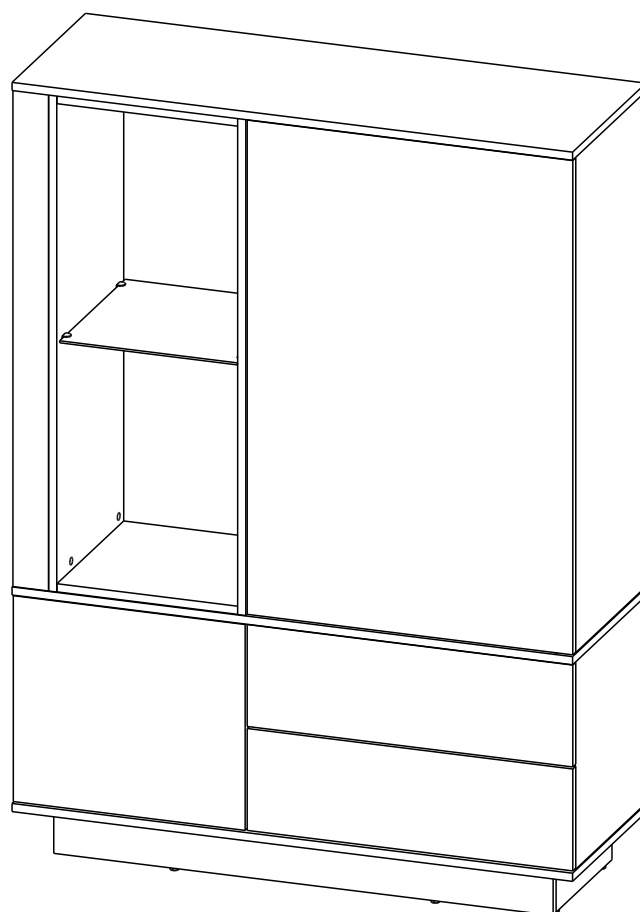

21A

RU Потребуется для сборки:
EN Required for assembly:

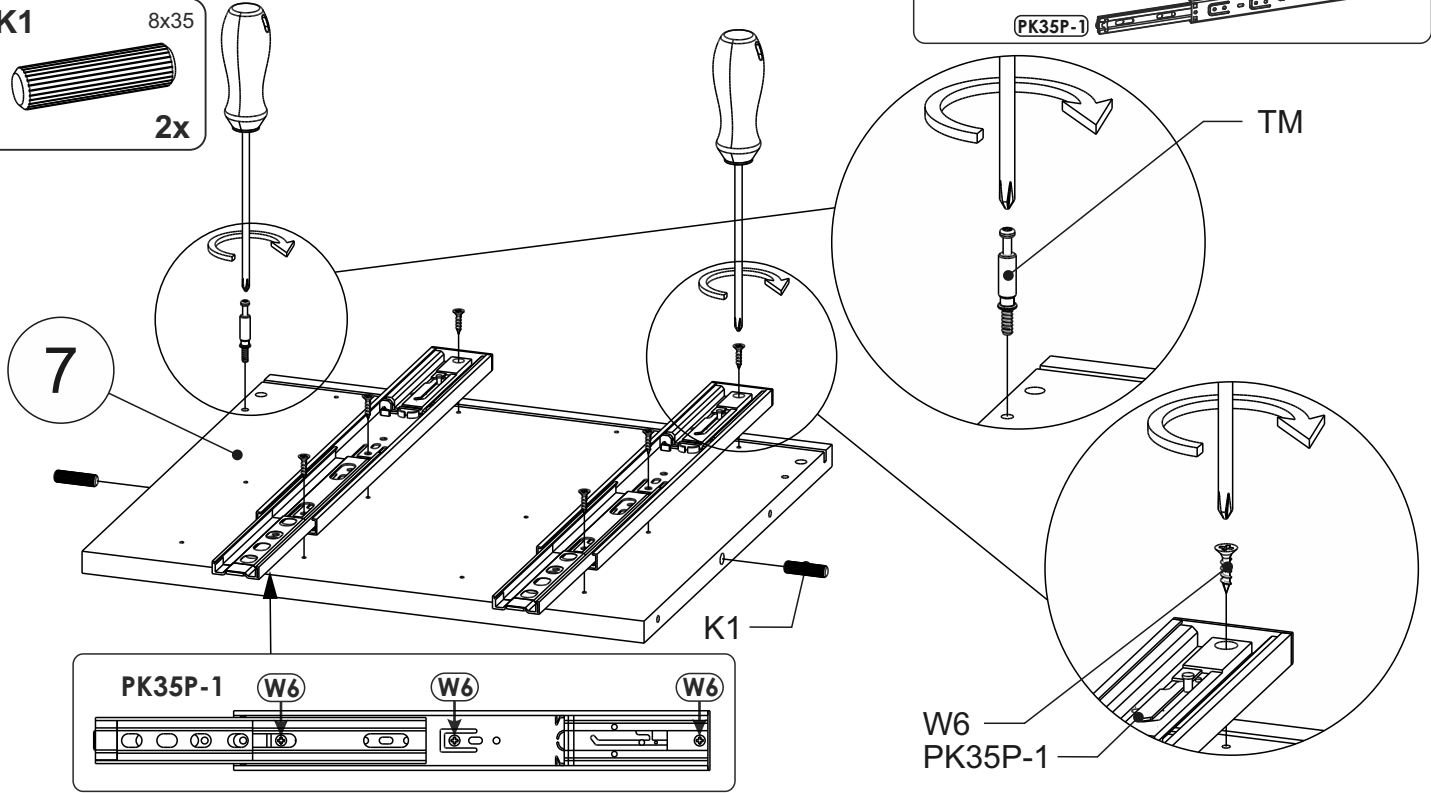
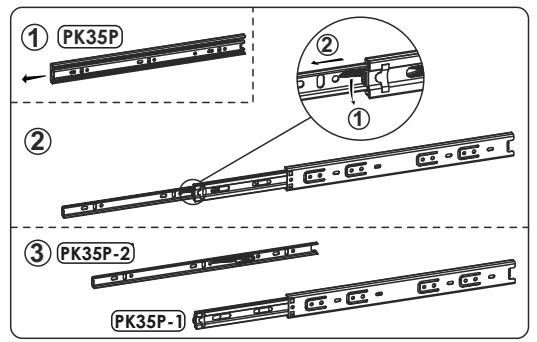
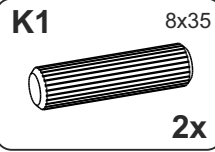
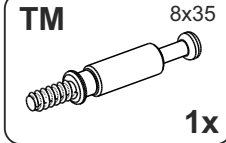
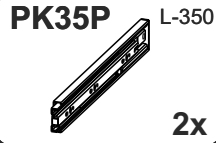
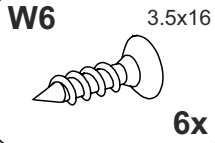

22A

RU Потребуется для сборки:
EN Required for assembly:

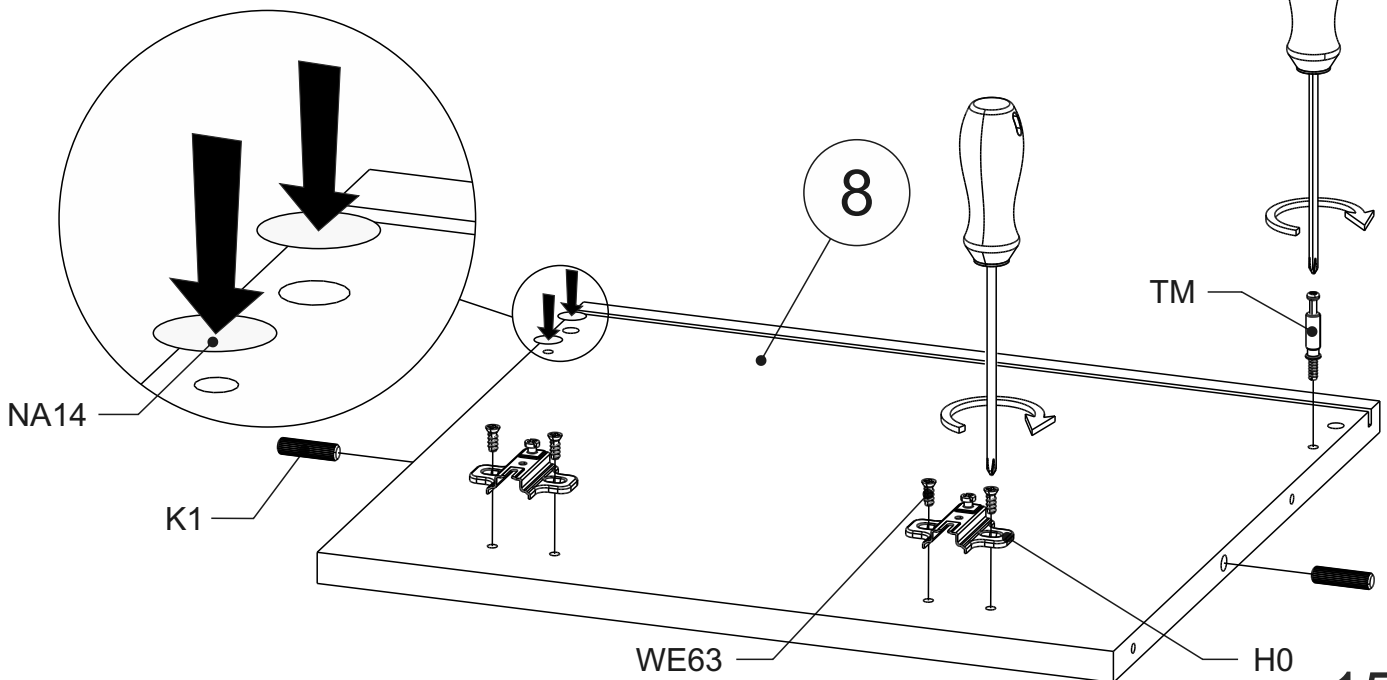
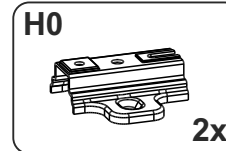
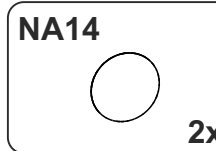
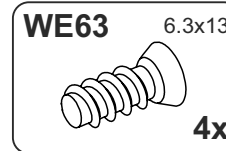
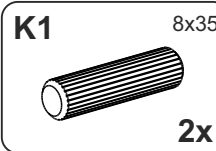
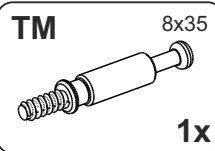

23A

RU Потребуется для сборки: 
EN Required for assembly:

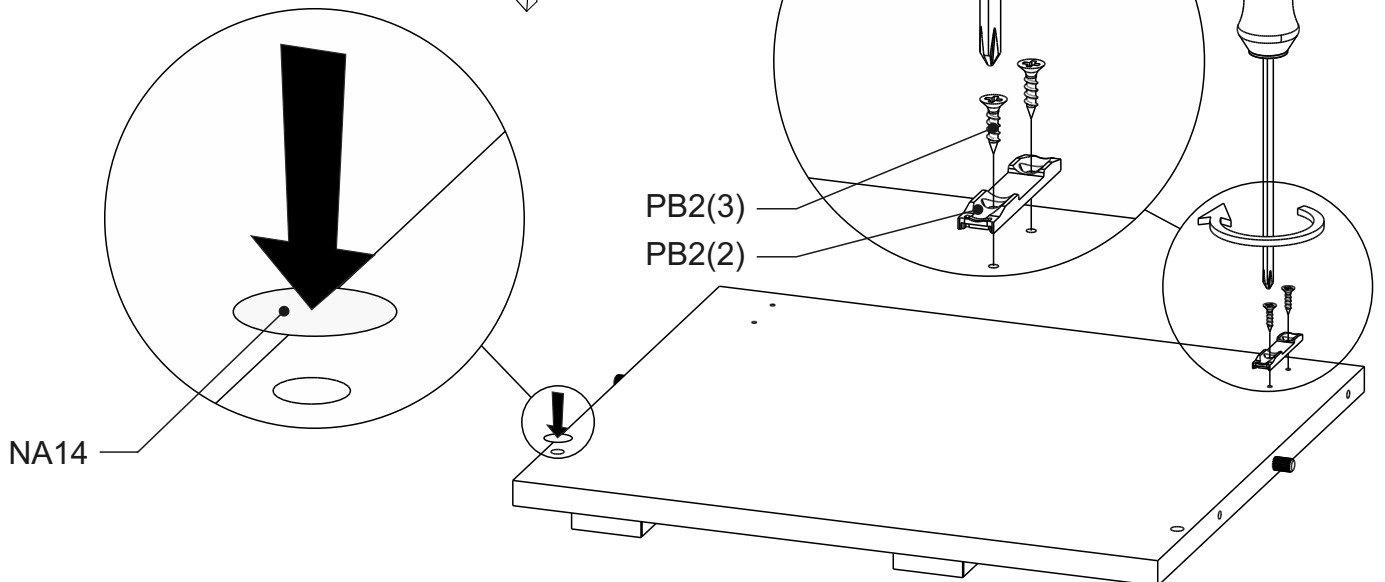
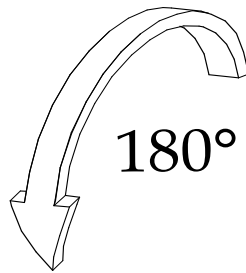
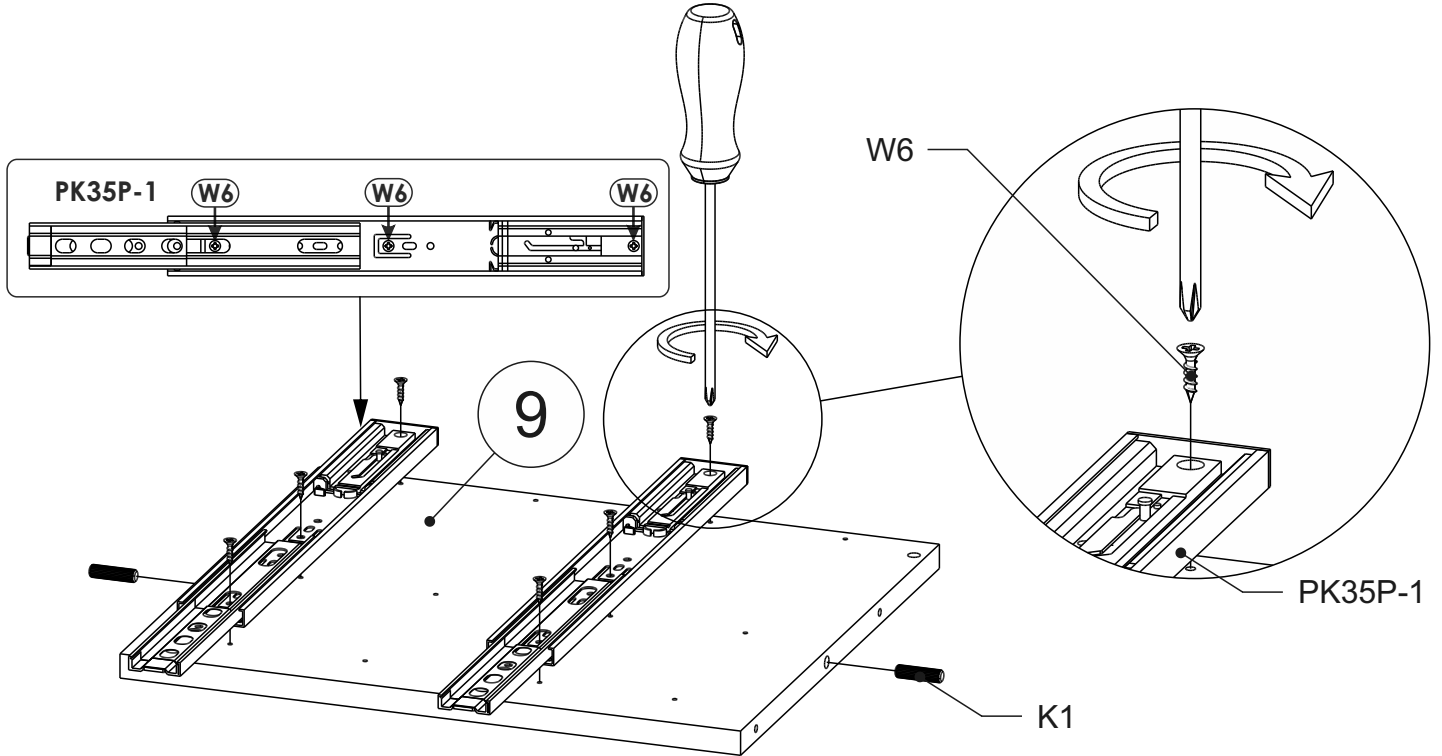
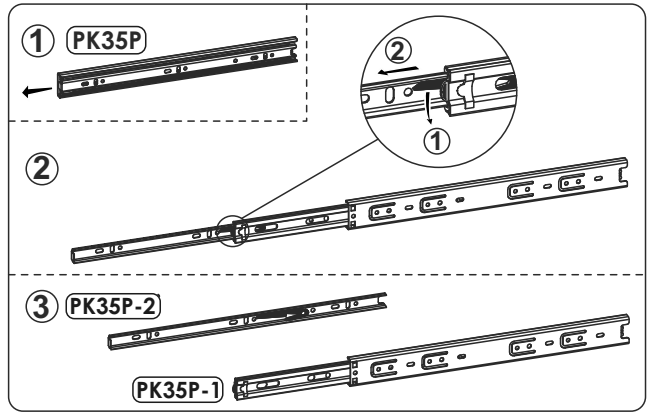
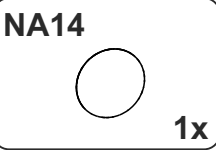
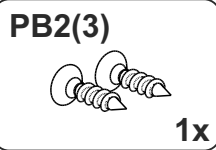
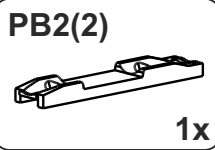
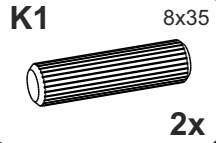
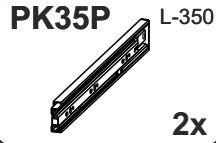
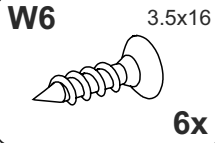

24A

RU Потребуется для сборки:
EN Required for assembly:

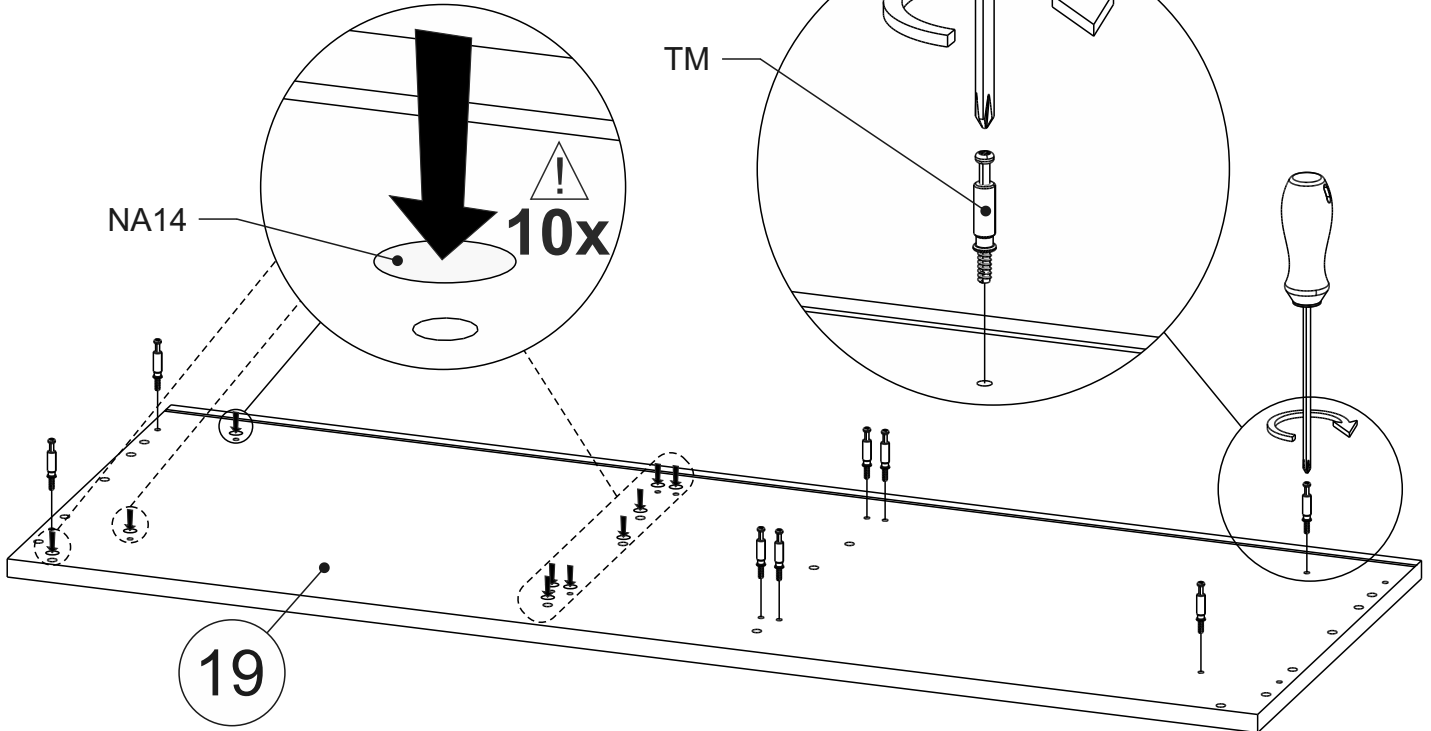
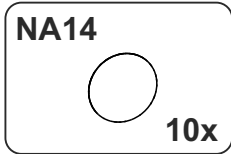
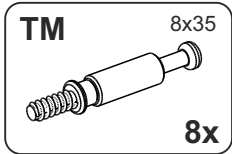
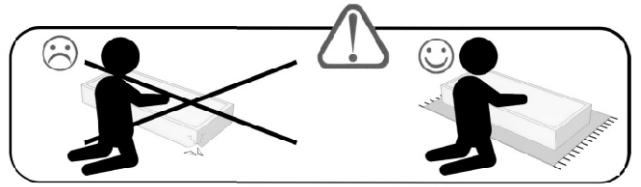

25A

RU Потребуется для сборки:
EN Required for assembly:

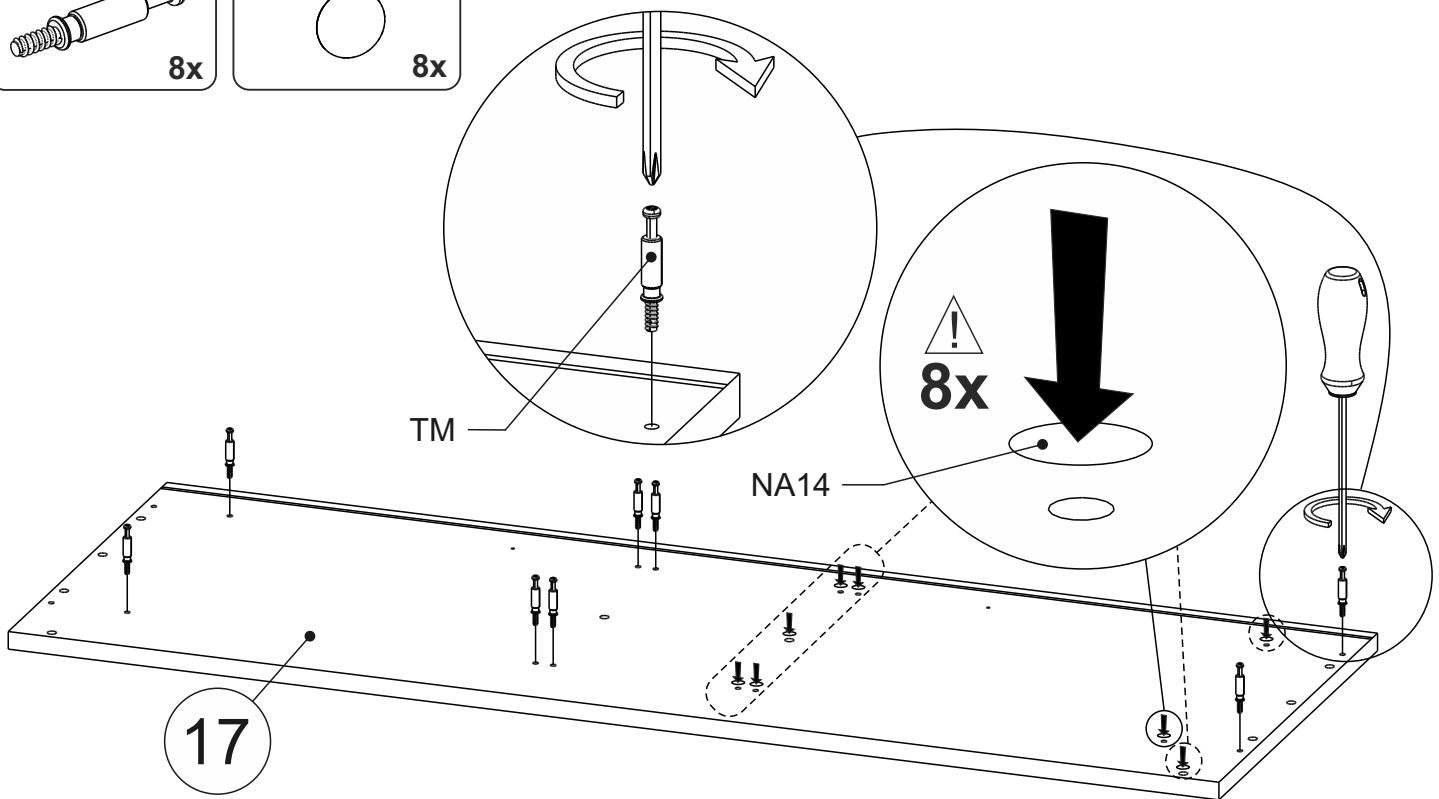
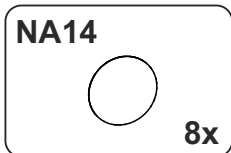
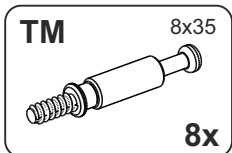
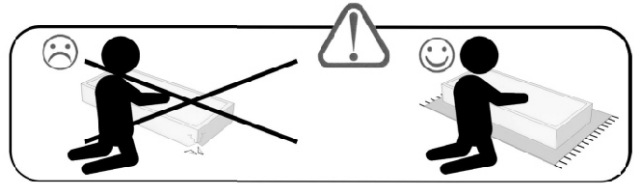

26A

RU Потребуется для сборки:
EN Required for assembly:

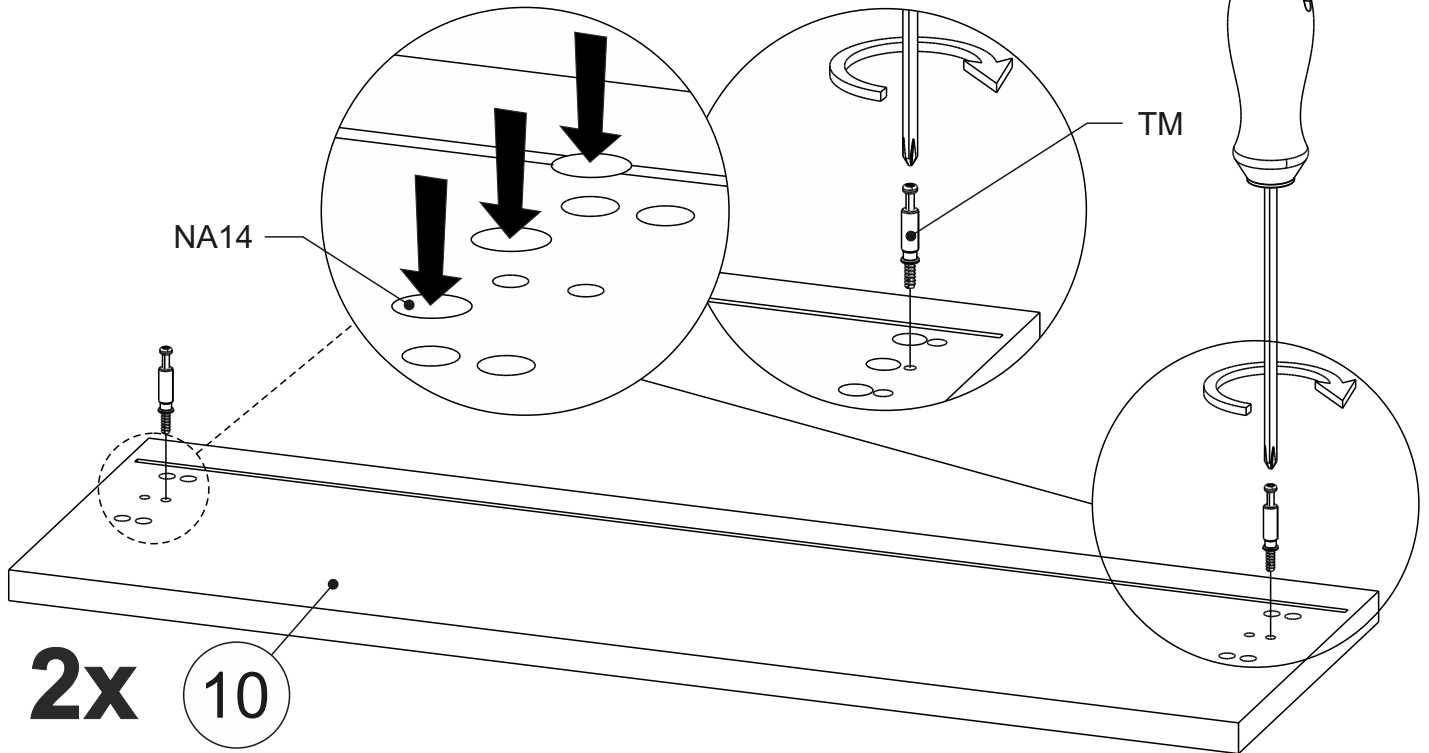
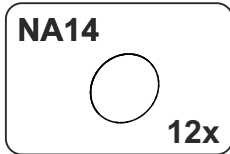
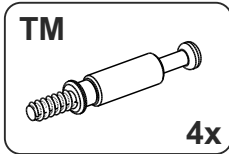
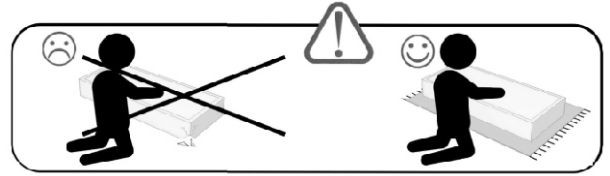

2x 10

27A

RU Потребуется для сборки:
EN Required for assembly:

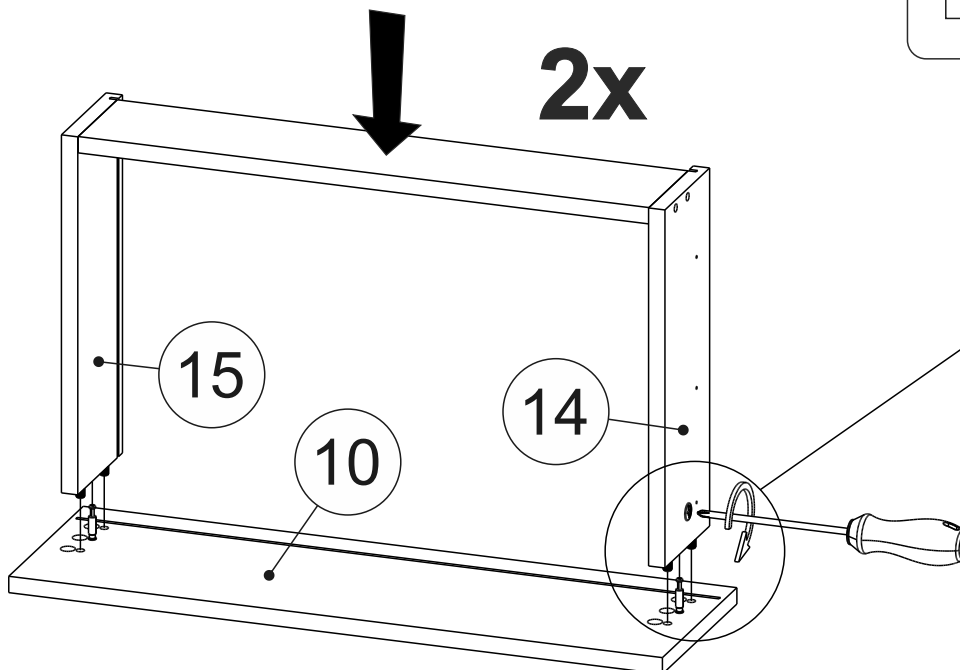
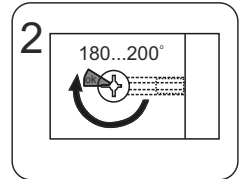
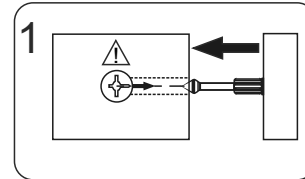
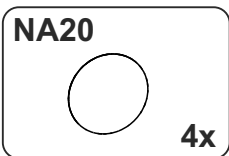
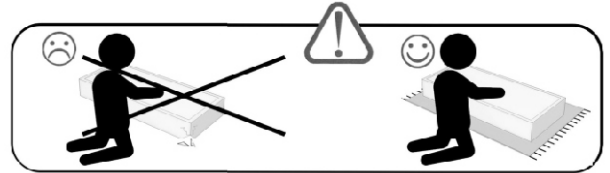

2x

NA20

28A

RU Потребуется для сборки:
EN Required for assembly:

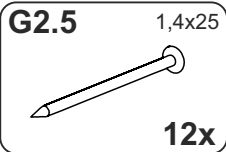
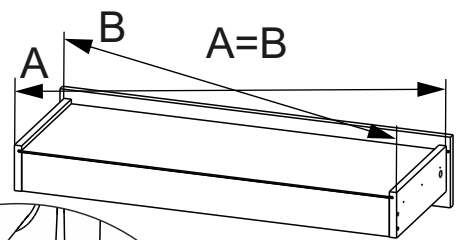

30

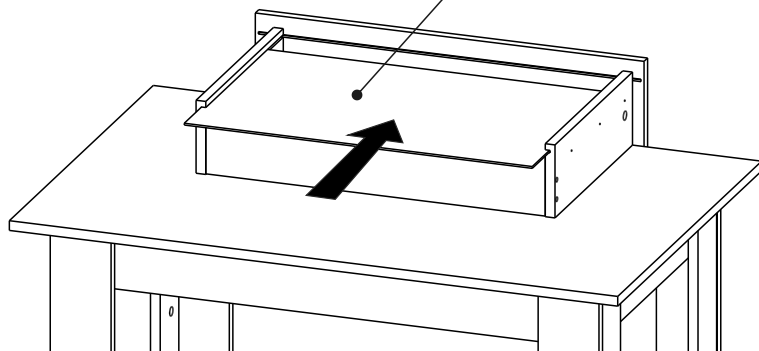

2x

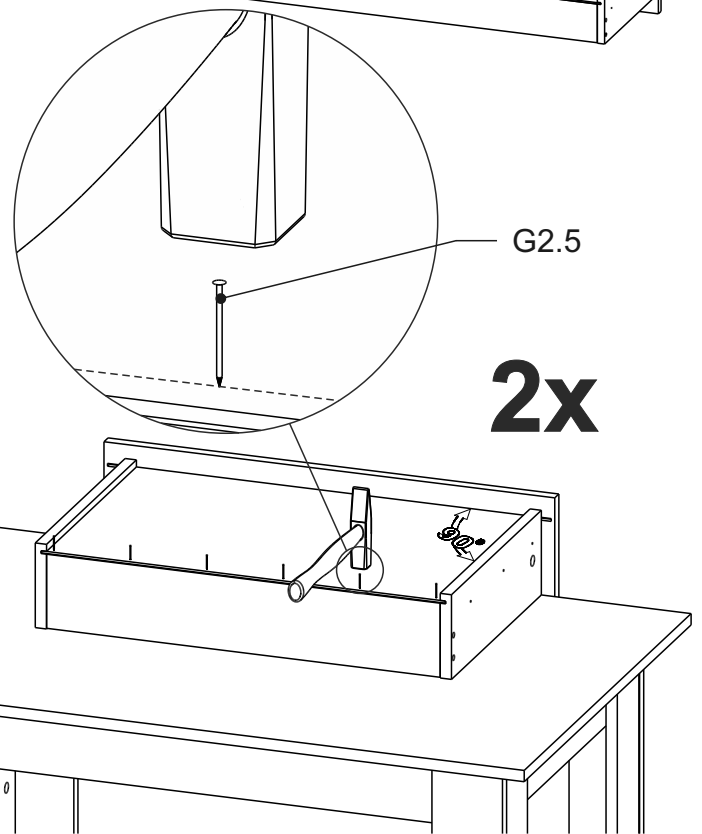

29A

RU Потребуется для сборки:
EN Required for assembly:

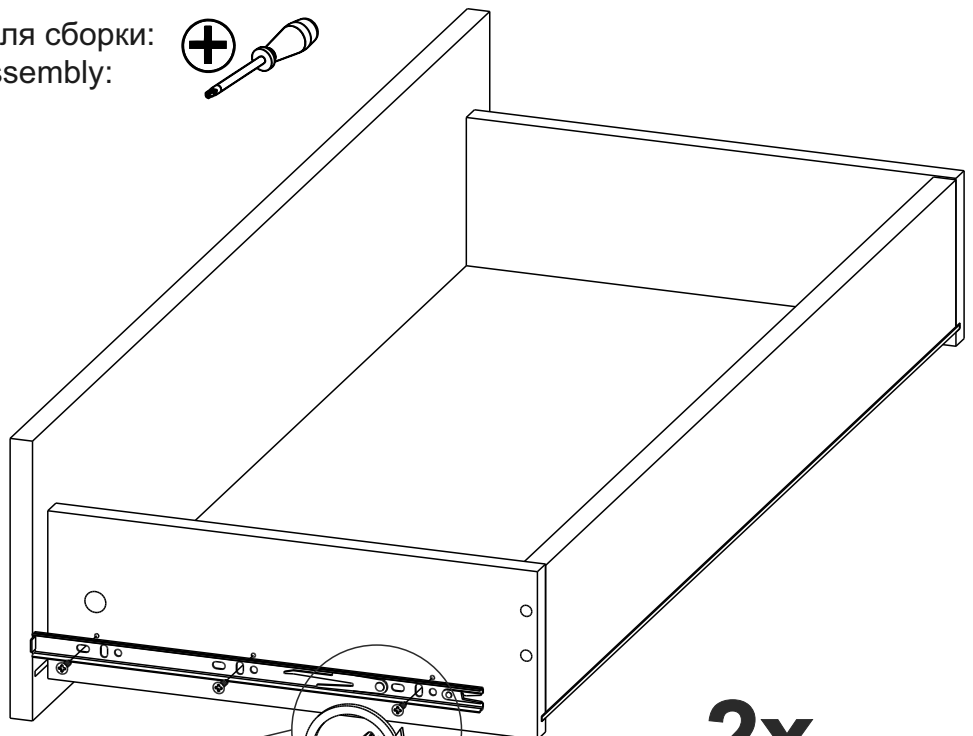
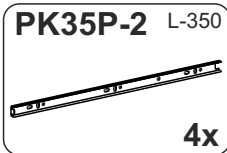
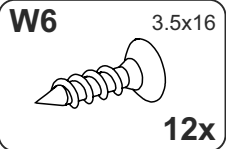

2x

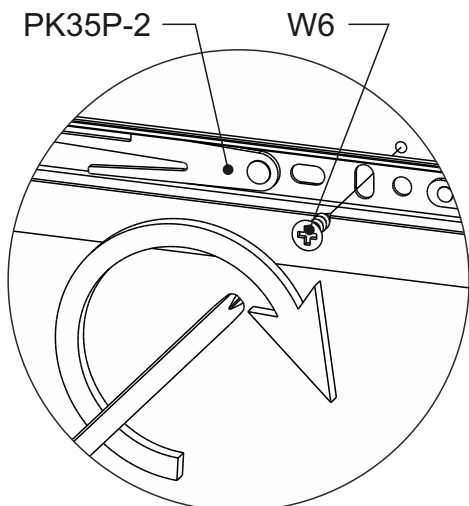

30A

RU Потребуется для сборки:
EN Required for assembly:

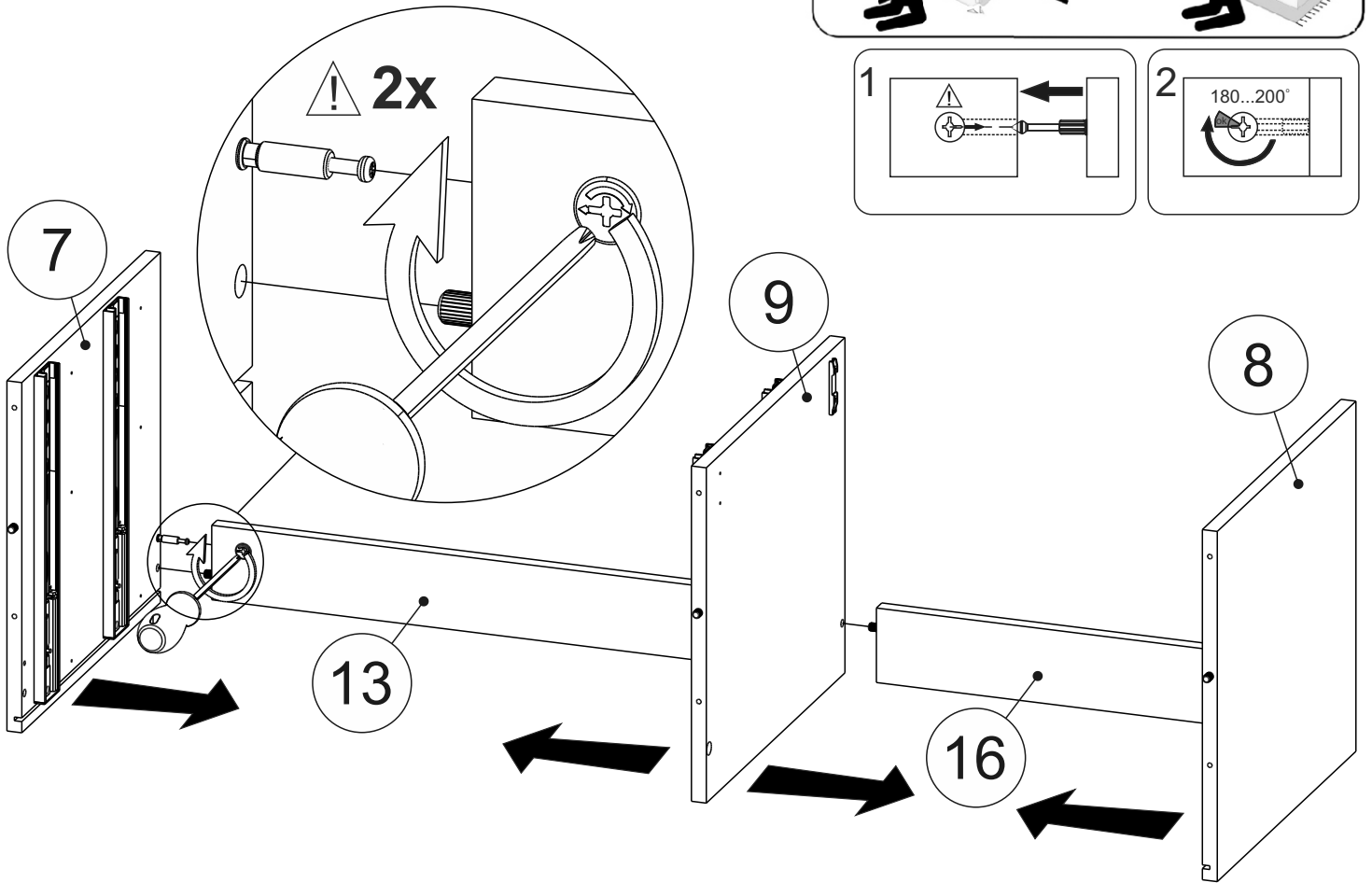
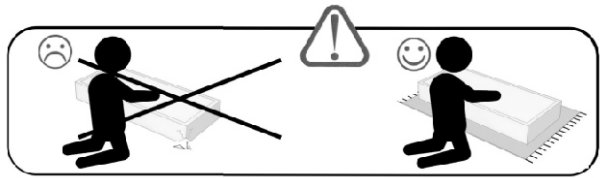

31A

RU Потребуется для сборки:
EN Required for assembly:

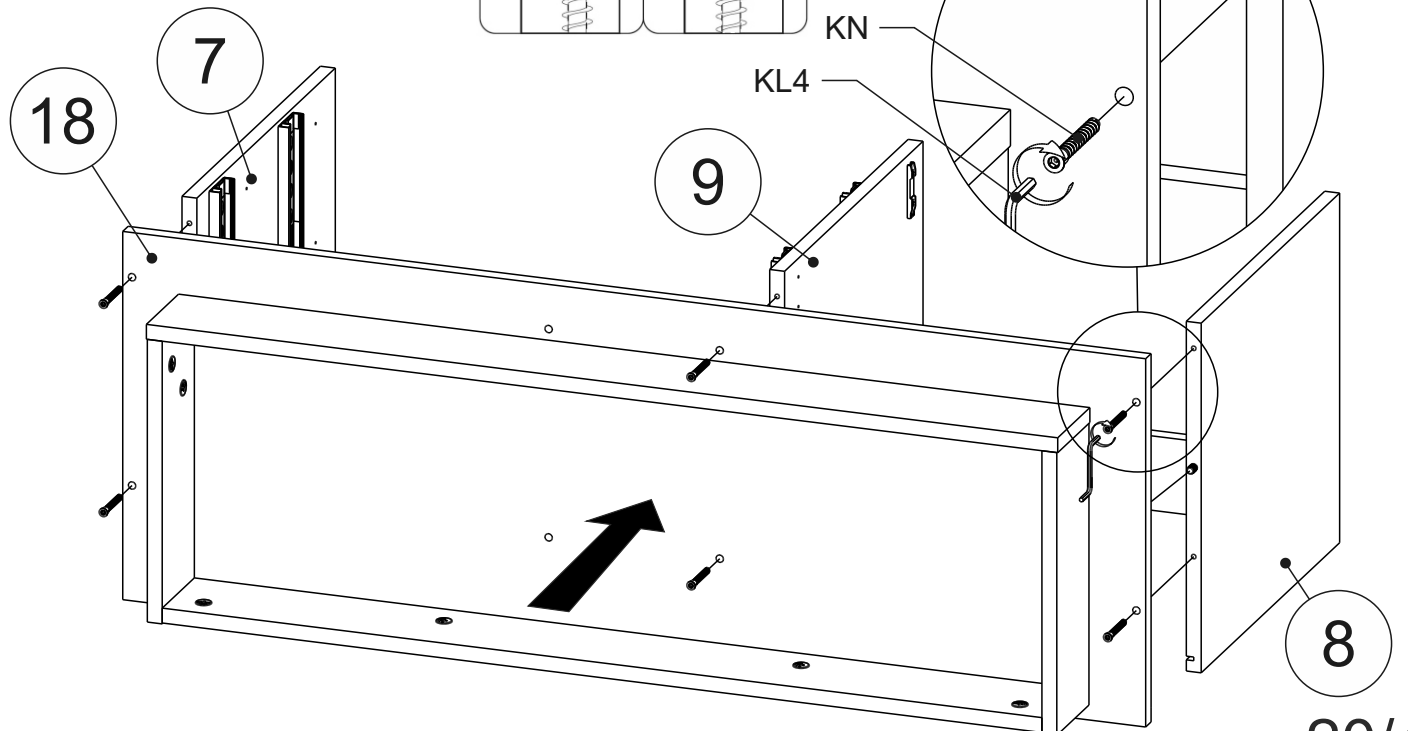
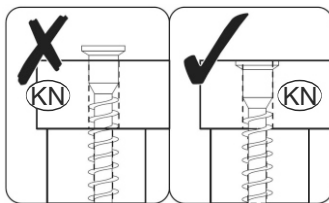
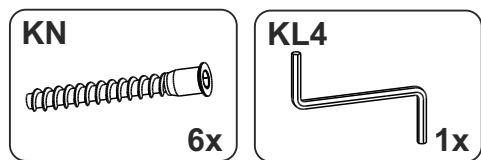
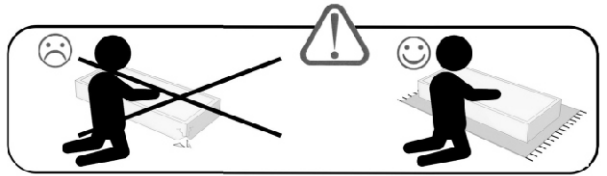

32A

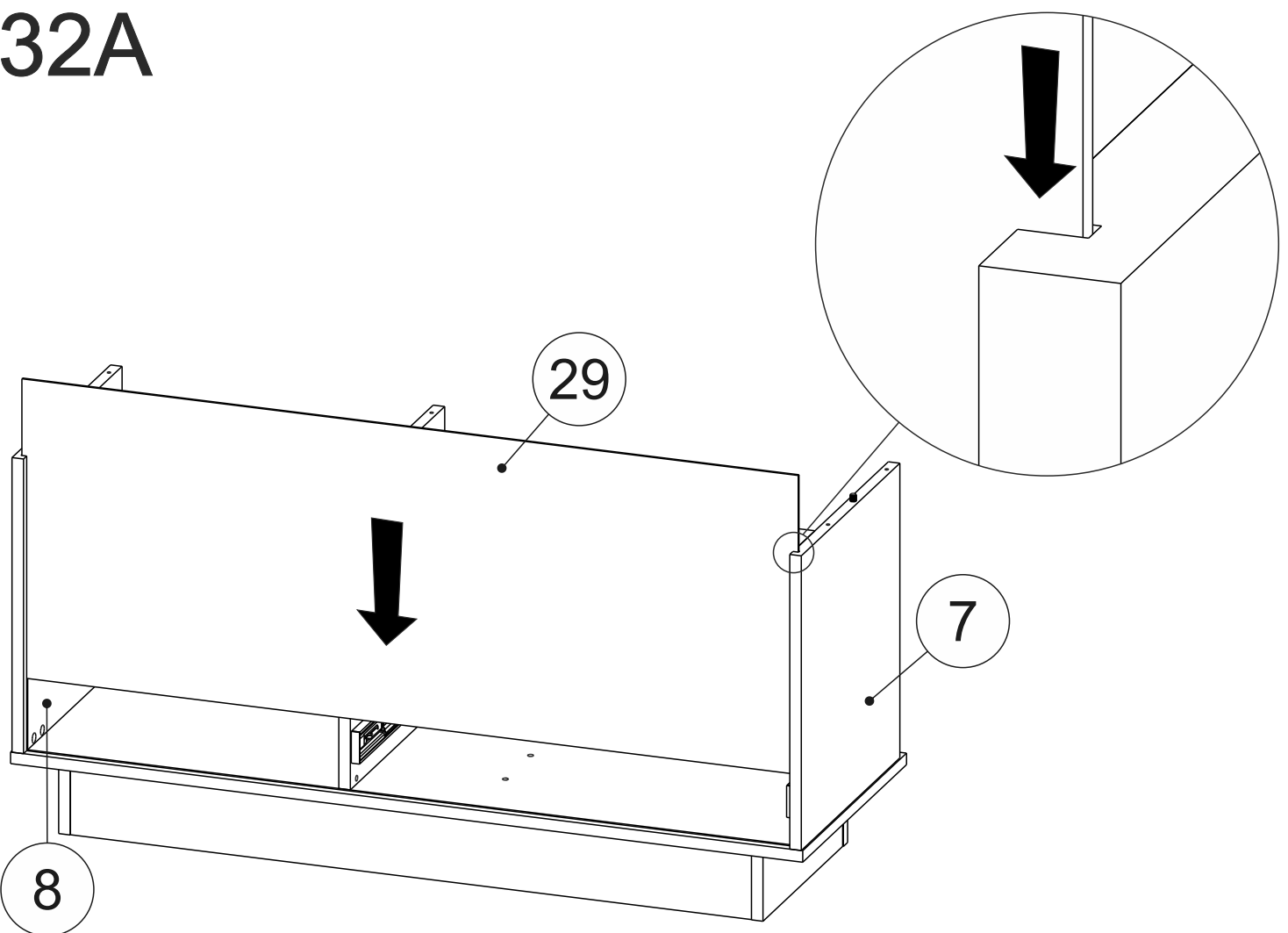

33A

RU Потребуется для сборки:
EN Required for assembly:

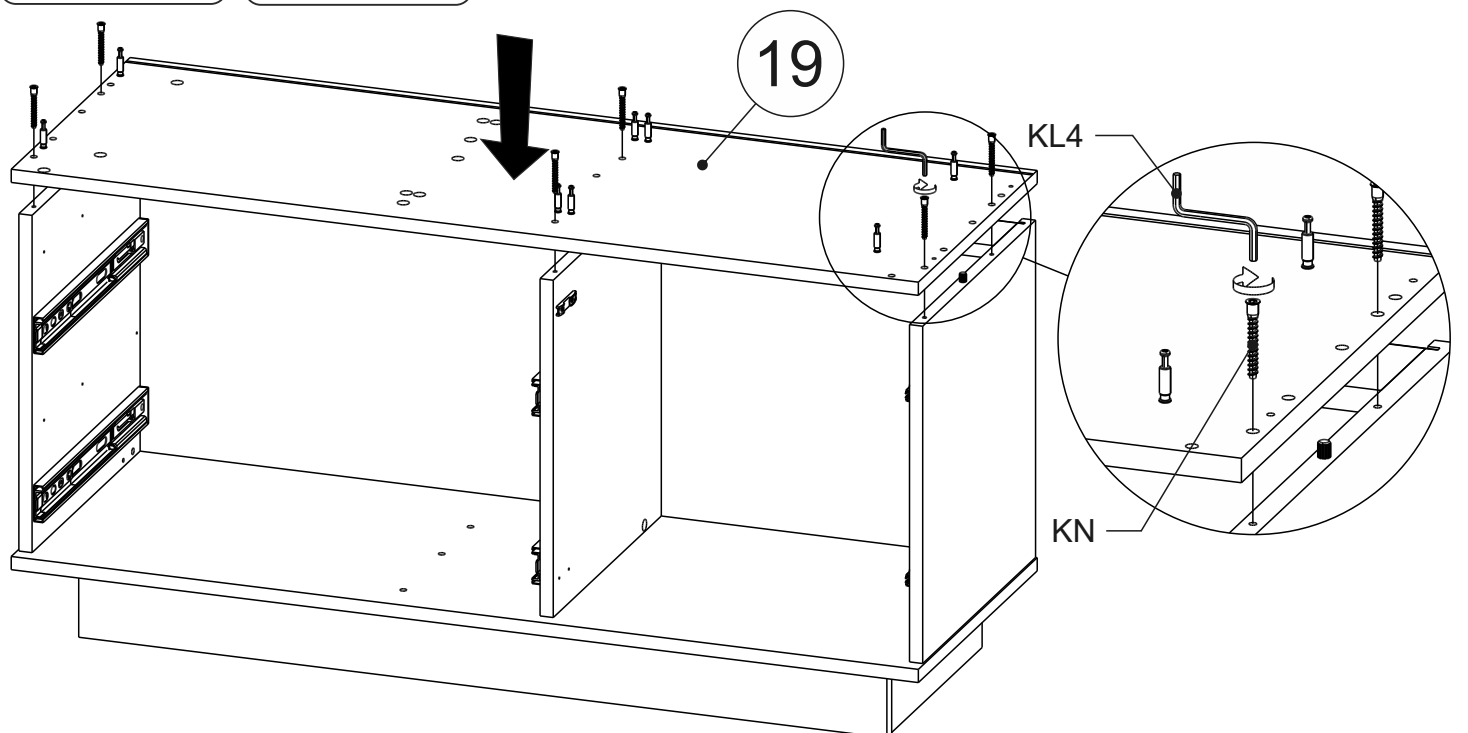
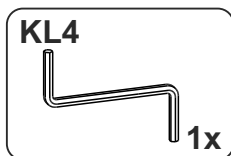
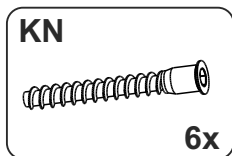
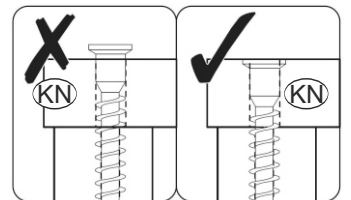

34A

RU Потребуется для сборки:
EN Required for assembly:

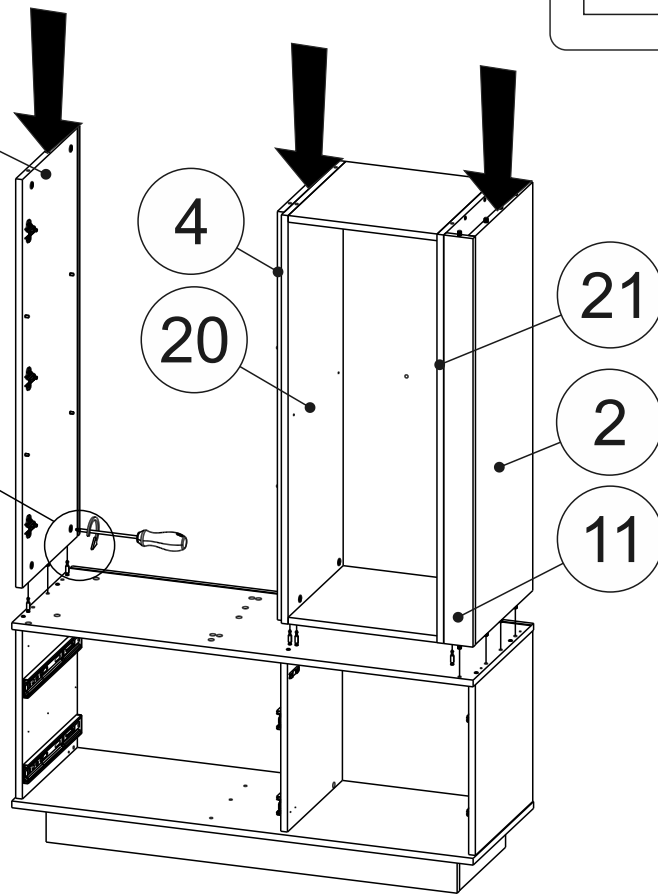
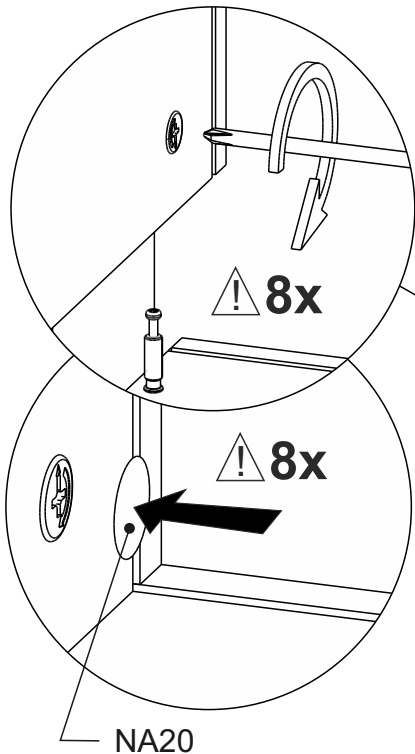
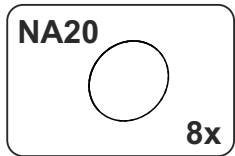
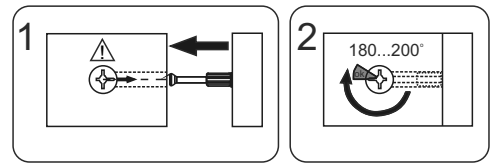

35A

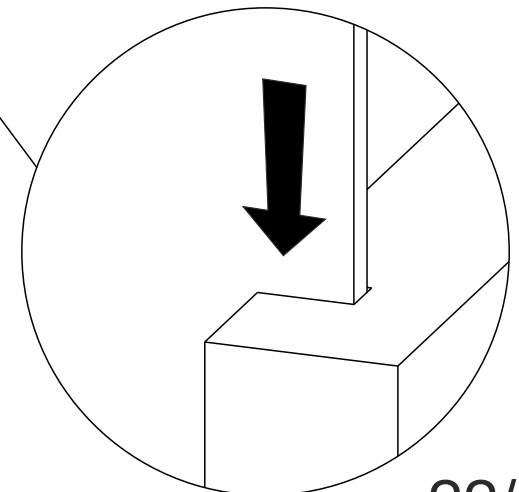
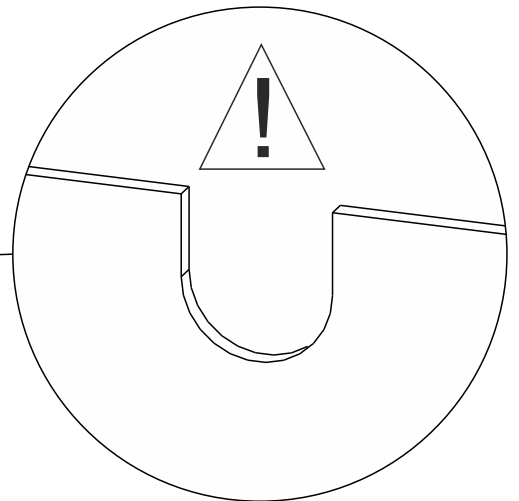
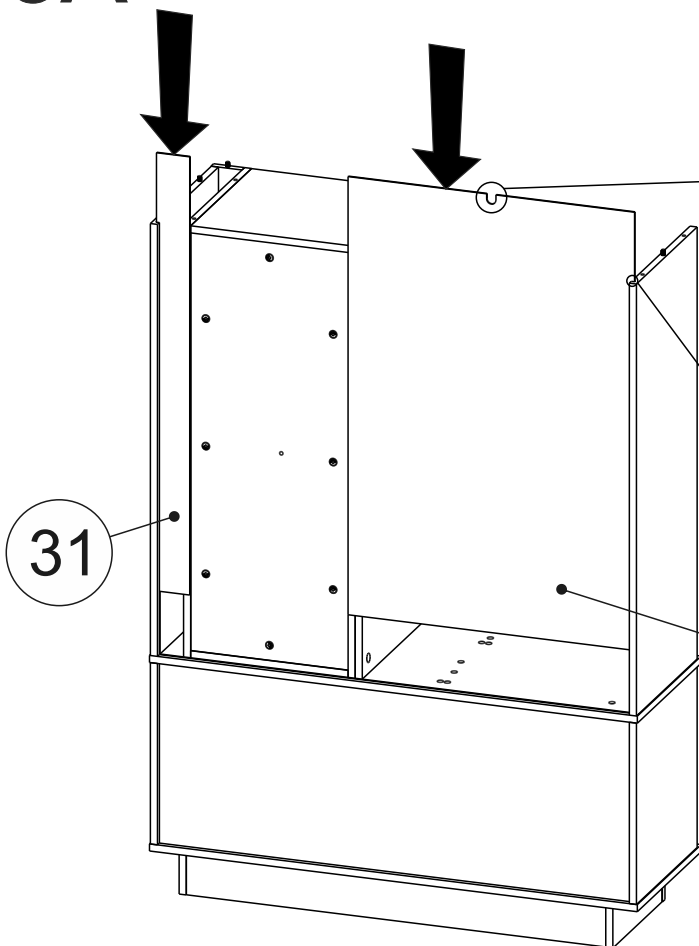

36A

RU Потребуется для сборки:
EN Required for assembly:

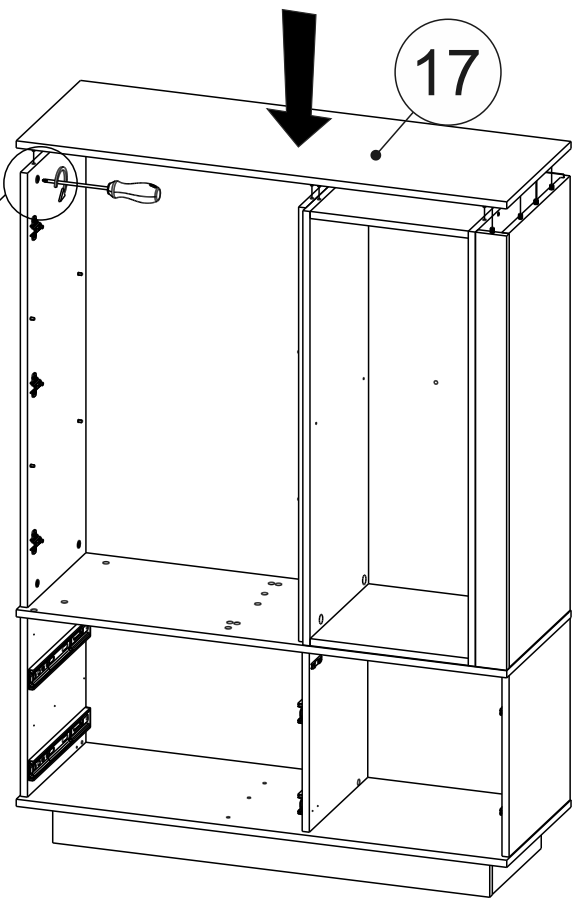
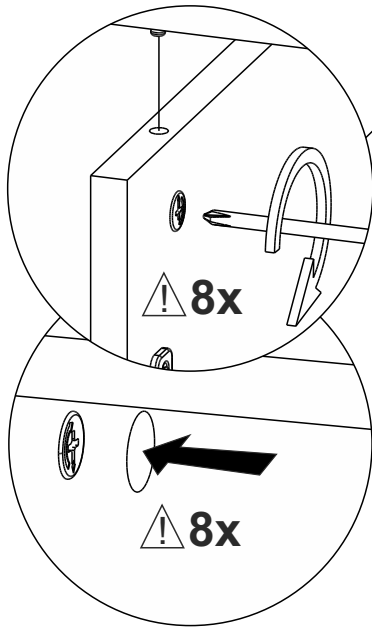
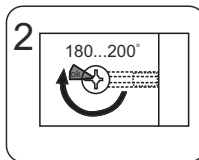
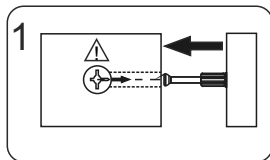
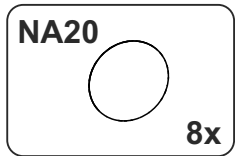

37A

RU Потребуется для сборки:
EN Required for assembly:

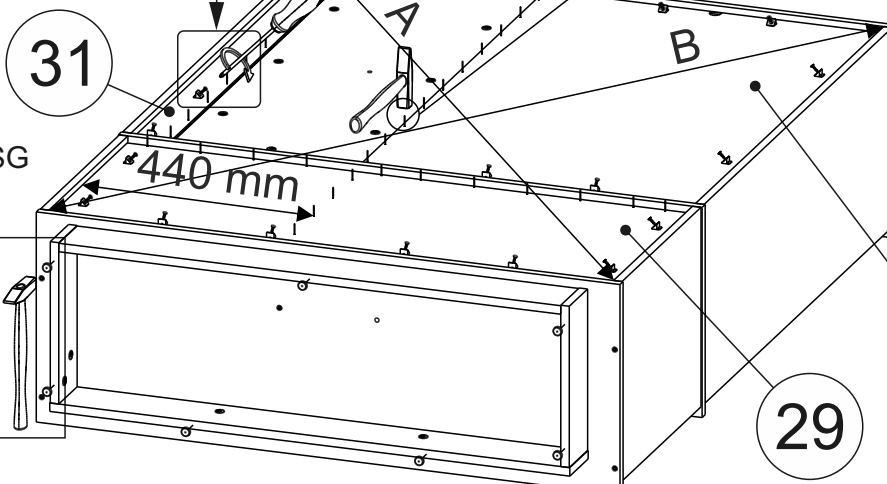
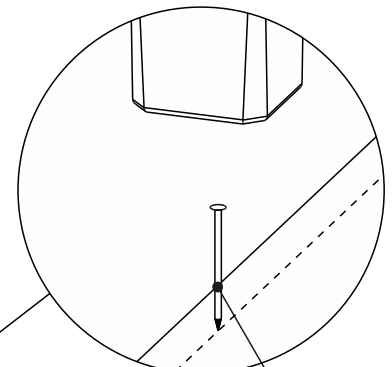
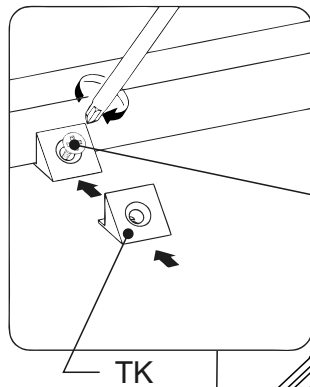
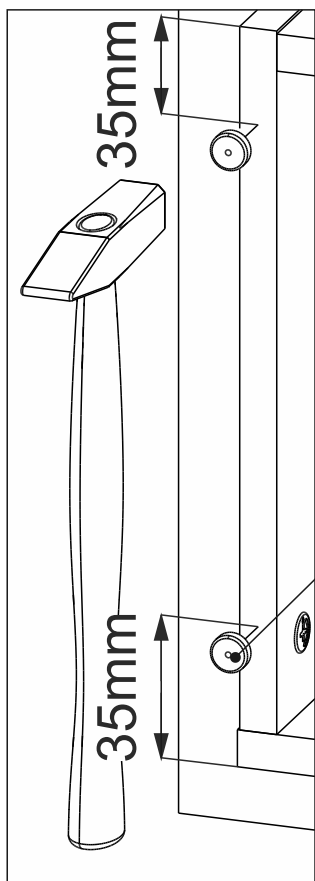
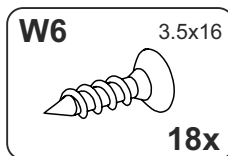
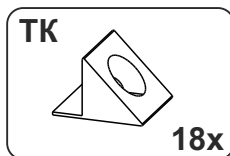
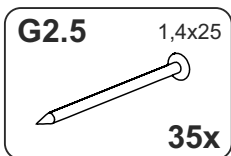
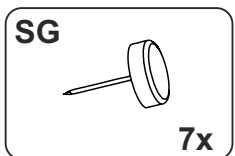
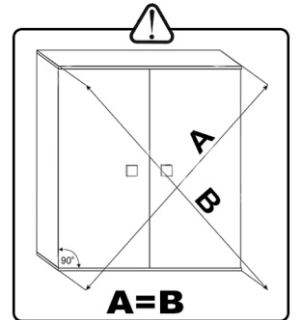

28

29

38A

RU Потребуется для сборки:
EN Required for assembly:

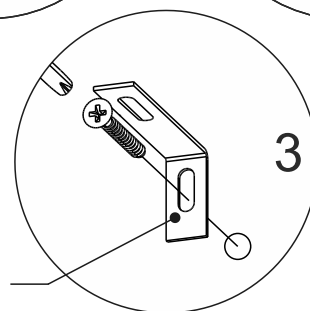
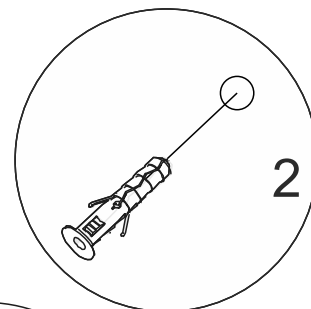
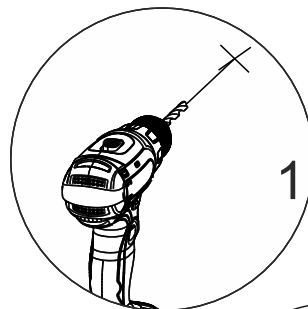
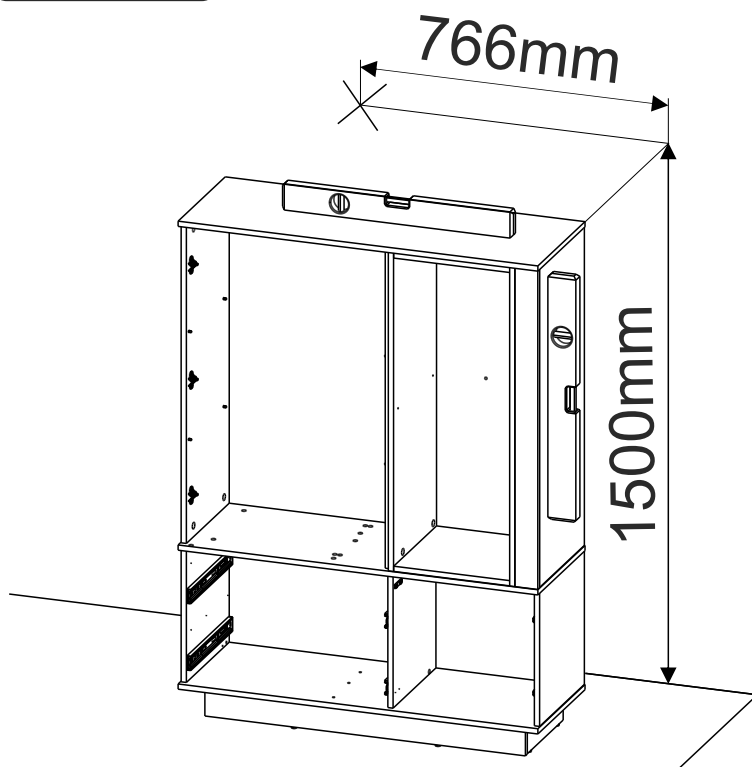
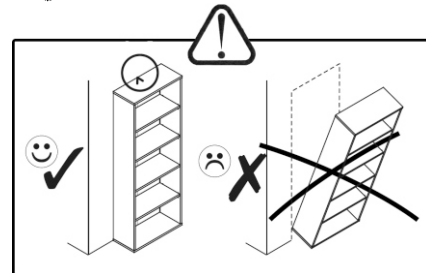
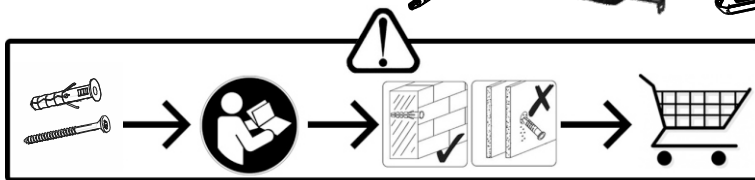
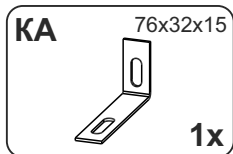

39A

RU Потребуется для сборки:
EN Required for assembly:

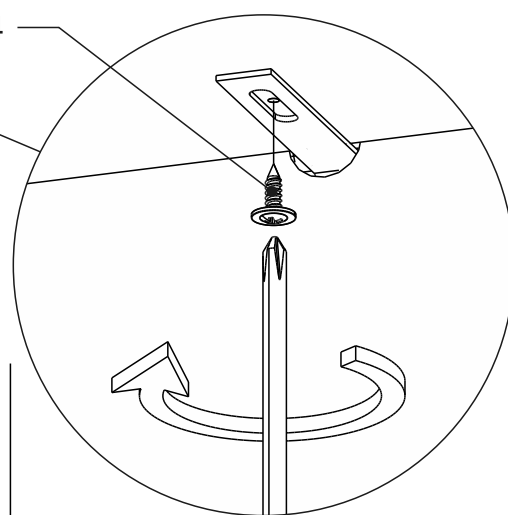
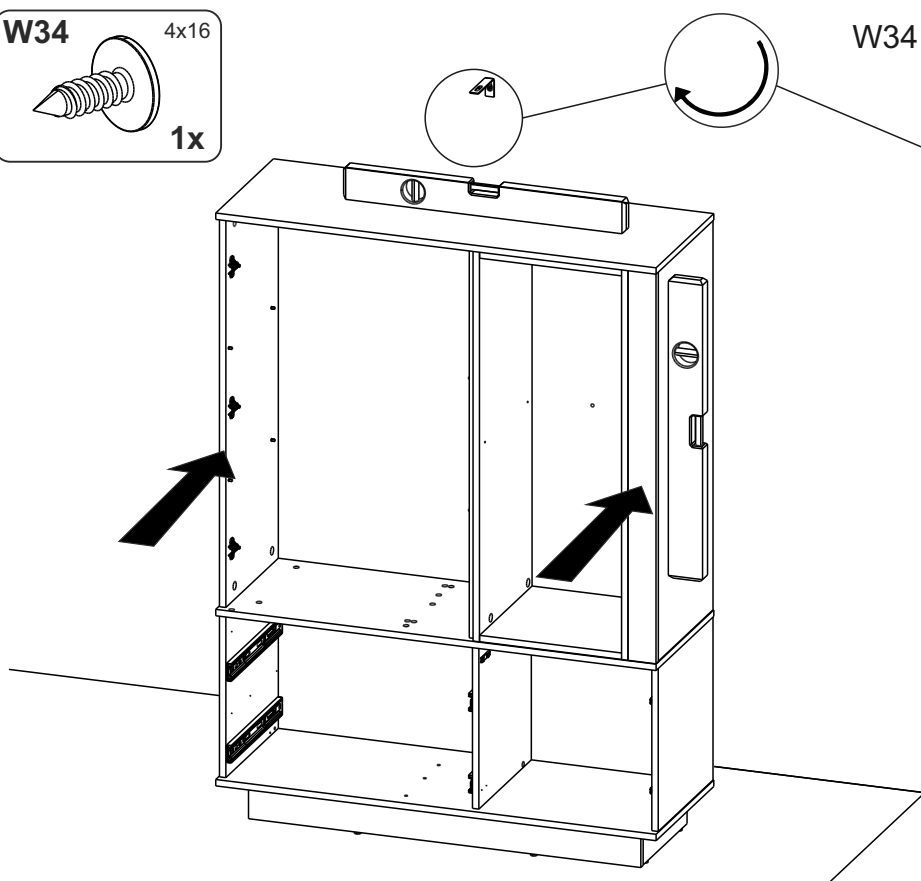
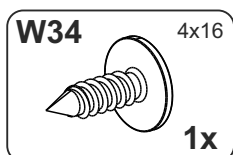
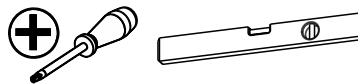

40A

RU Потребуется для сборки:
EN Required for assembly:

MV09



4x

PB2(1)



PB2(2)

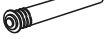

2x

20

21

4

9

PB2(1)

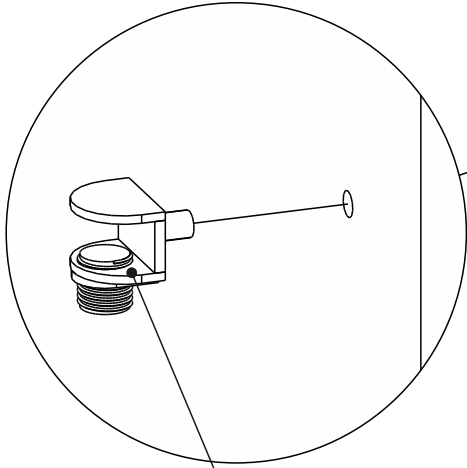
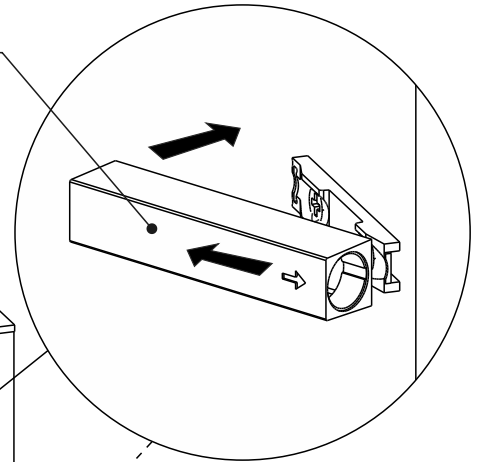

MV09

II

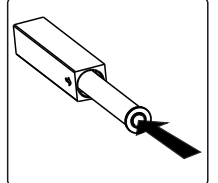

III

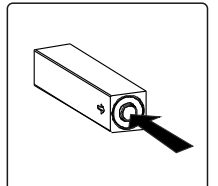

IV

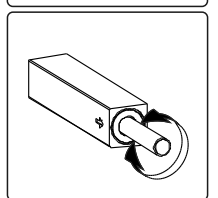

41A

RU Потребуется для сборки:
EN Required for assembly:

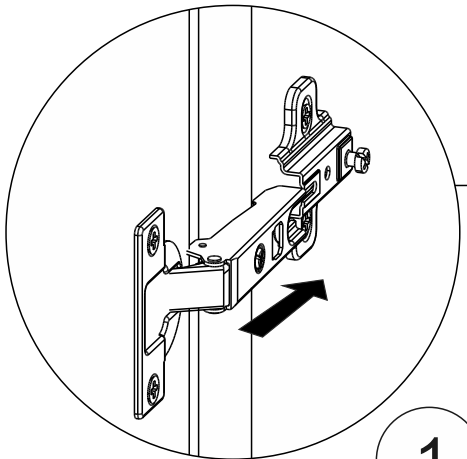

1

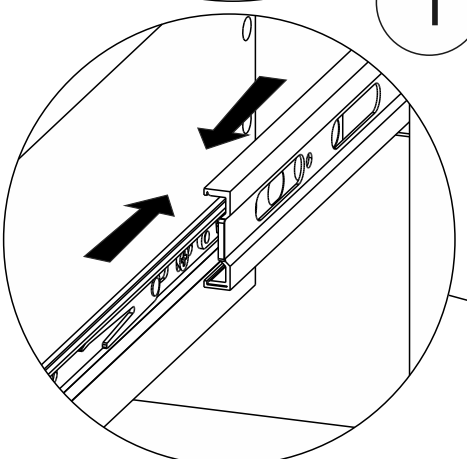

6

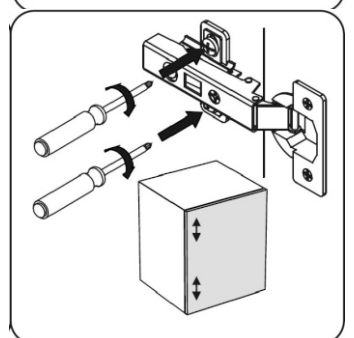
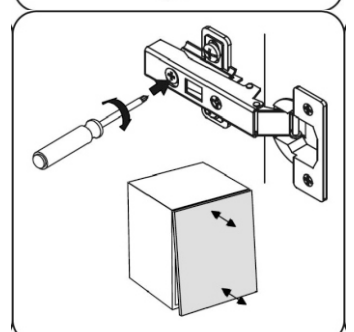
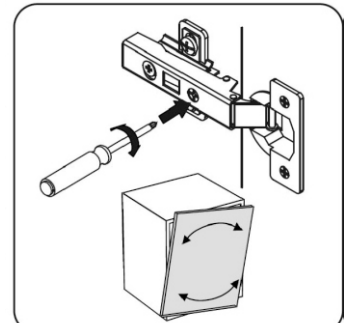

42A

RU Потребуется для сборки:
EN Required for assembly:



PB2(5)



PB2(4)

2x

1

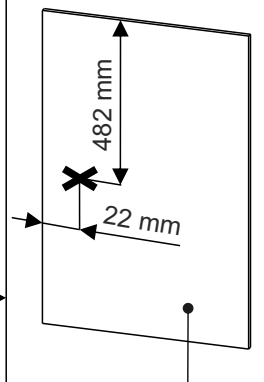
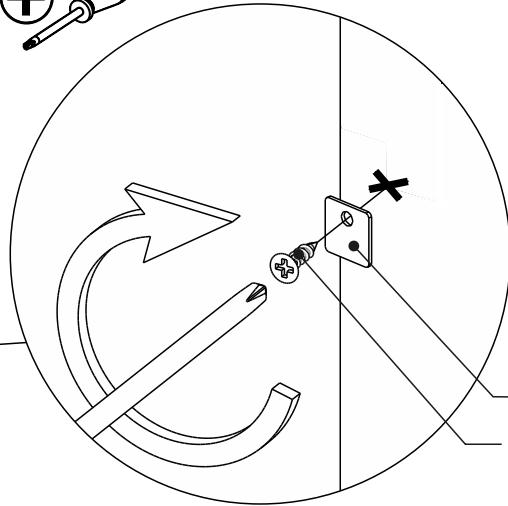
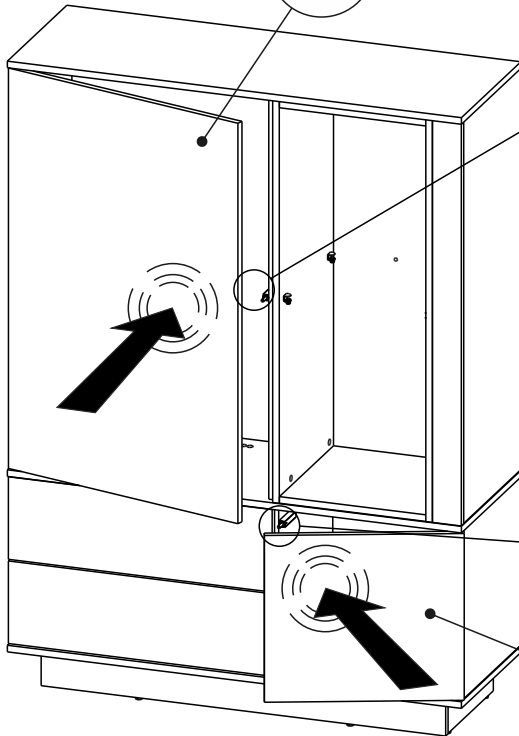

PB2(5)
PB2(4)

1

6

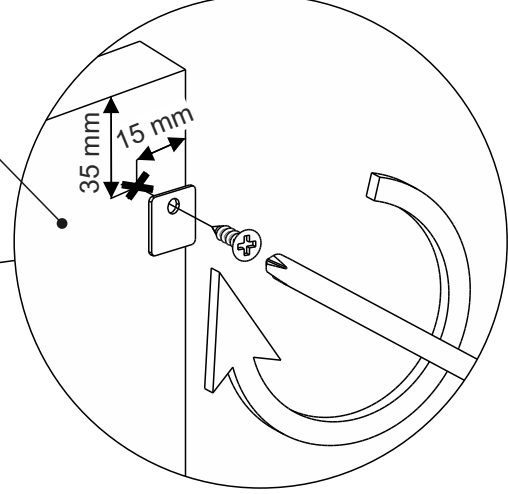

6

43A

RU Потребуется для сборки:
EN Required for assembly:

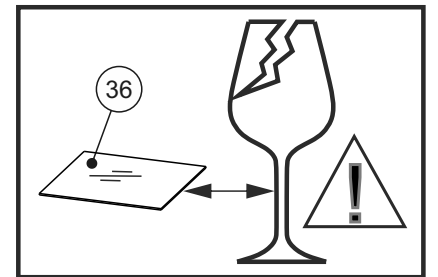

5

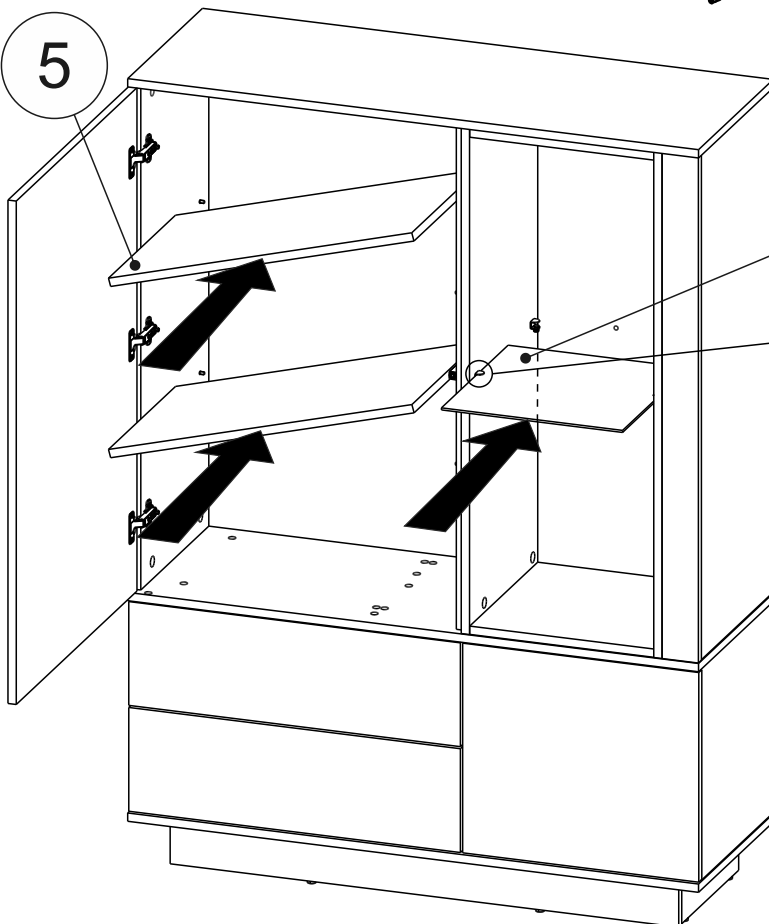

36

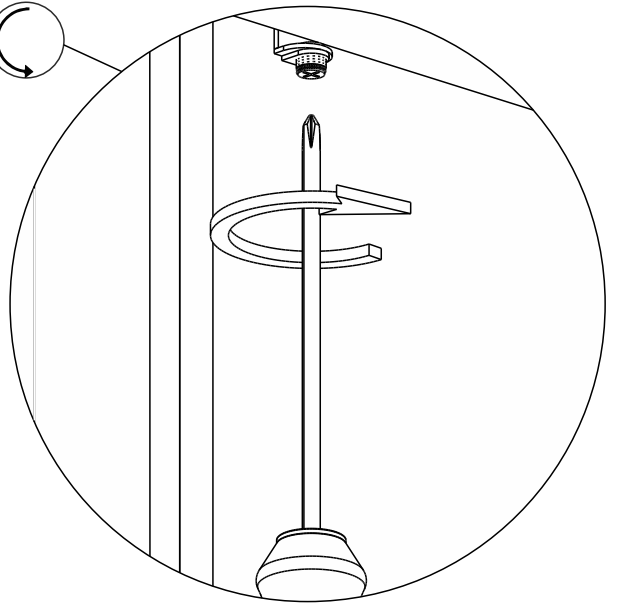

21B

RU Потребуется для сборки:
EN Required for assembly:

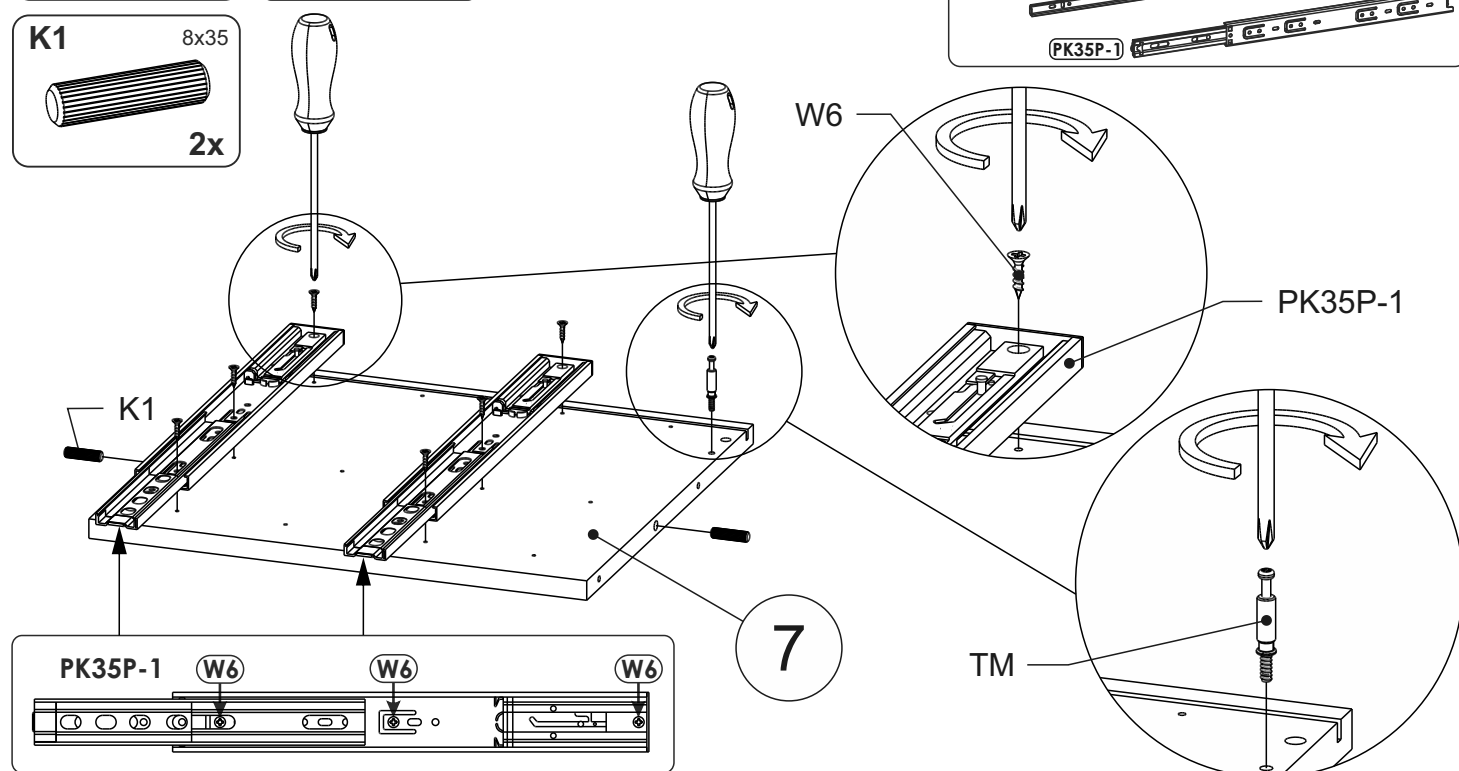
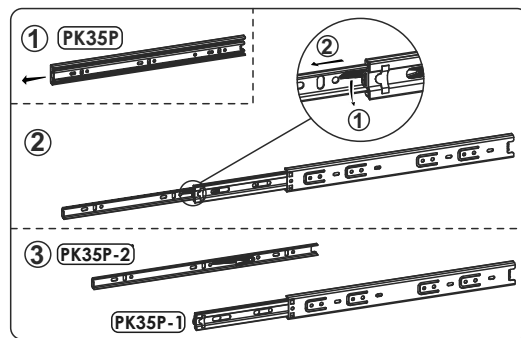
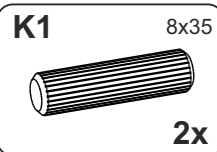
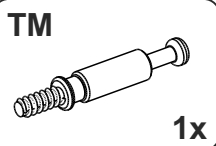
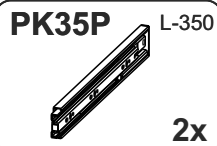
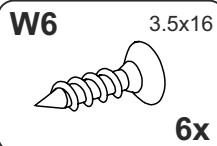

22B

RU Потребуется для сборки:
EN Required for assembly:

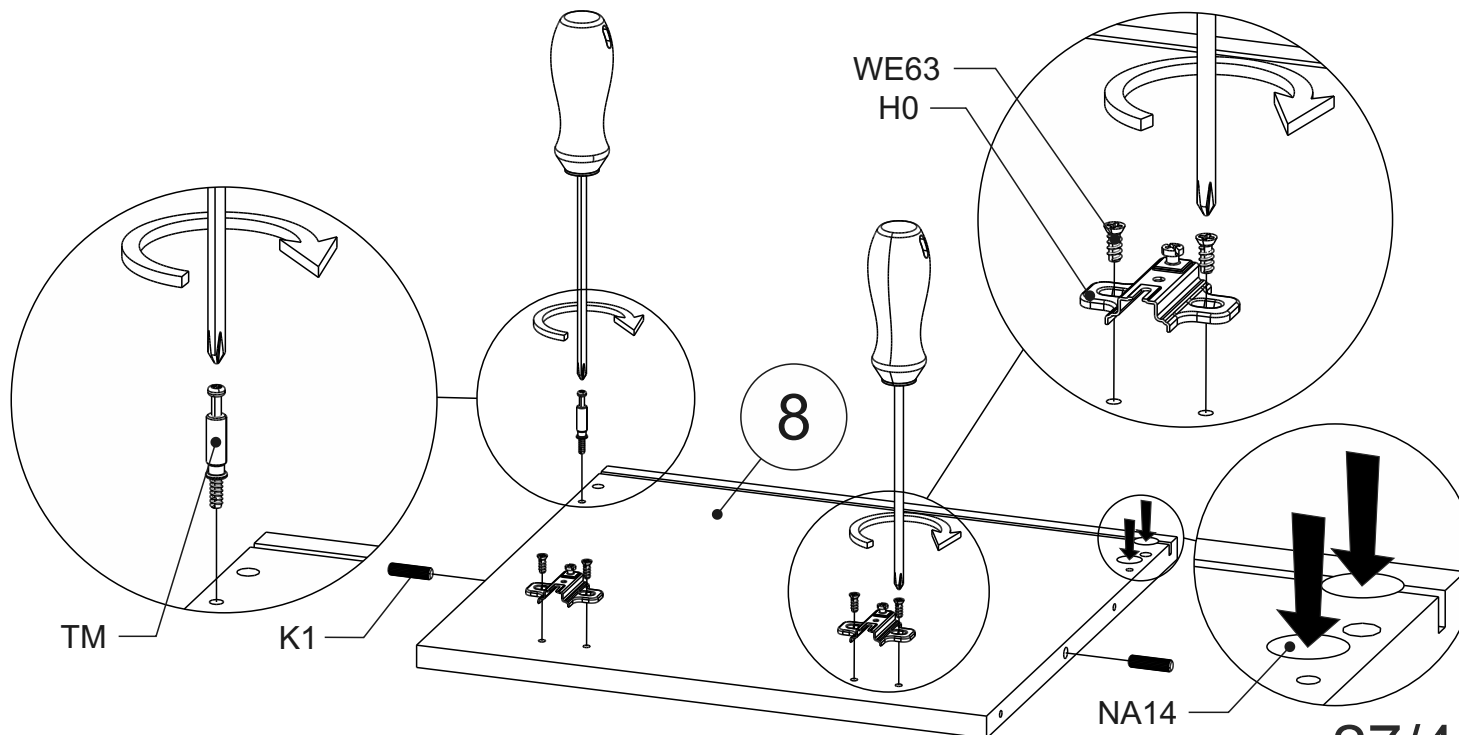
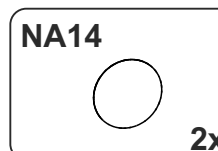
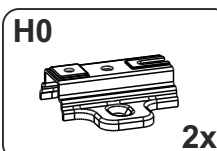
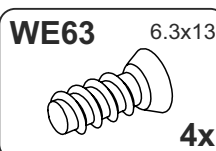
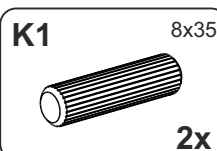
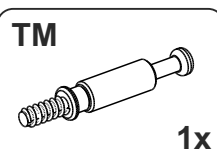

23B

RU Потребуется для сборки: 
EN Required for assembly:

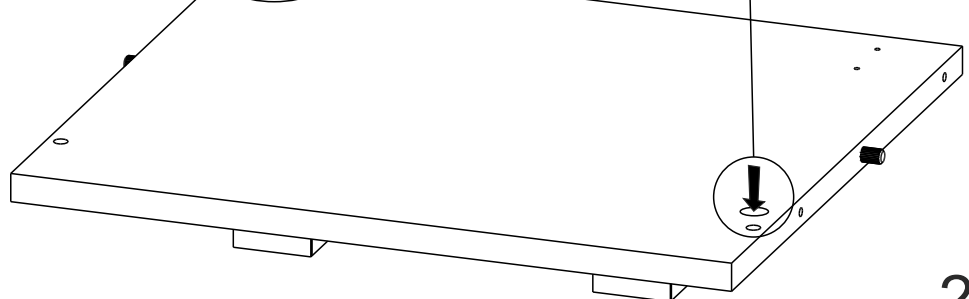
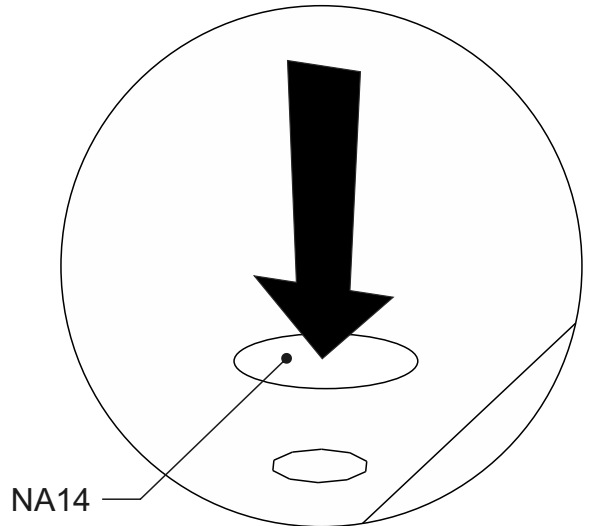
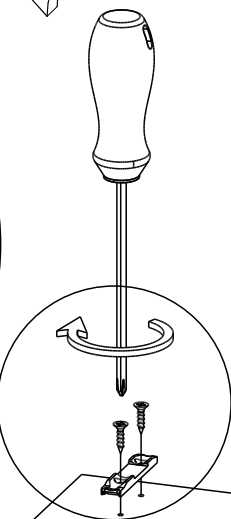
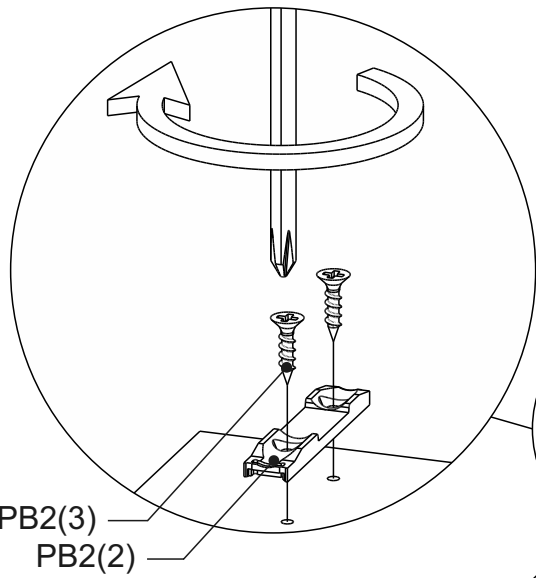
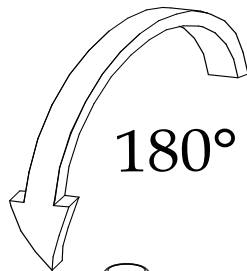
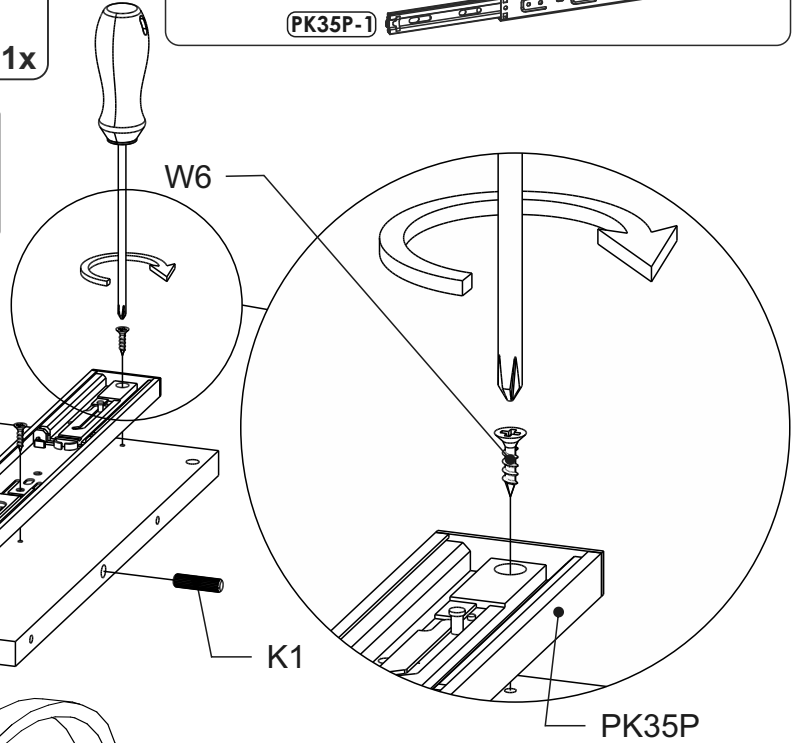
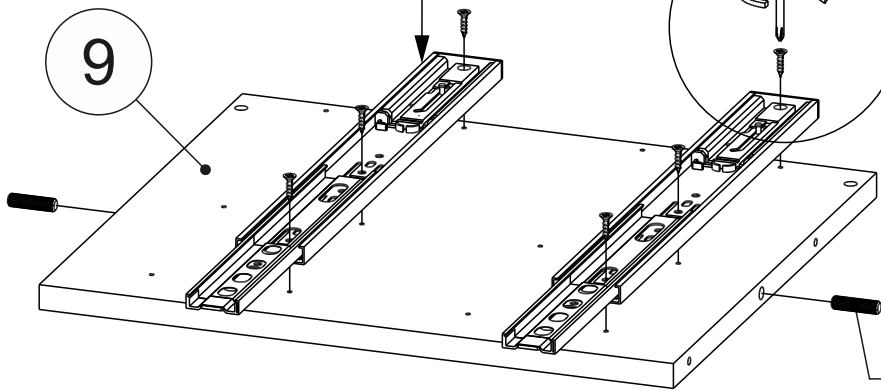
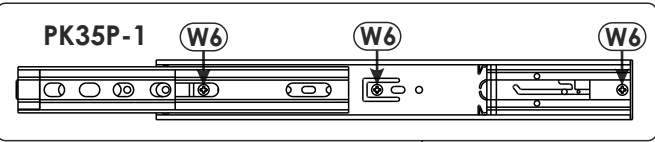
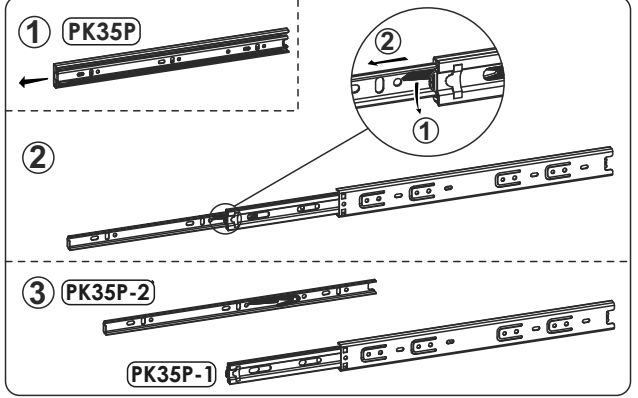
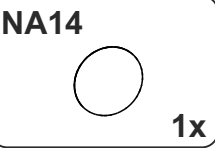
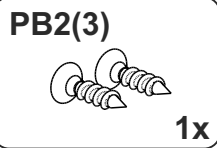
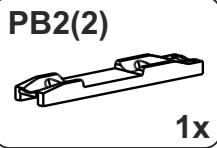
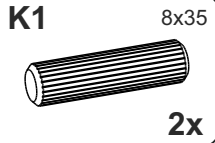
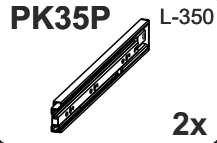
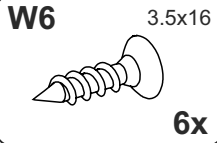

24B

RU Потребуется для сборки:
EN Required for assembly:

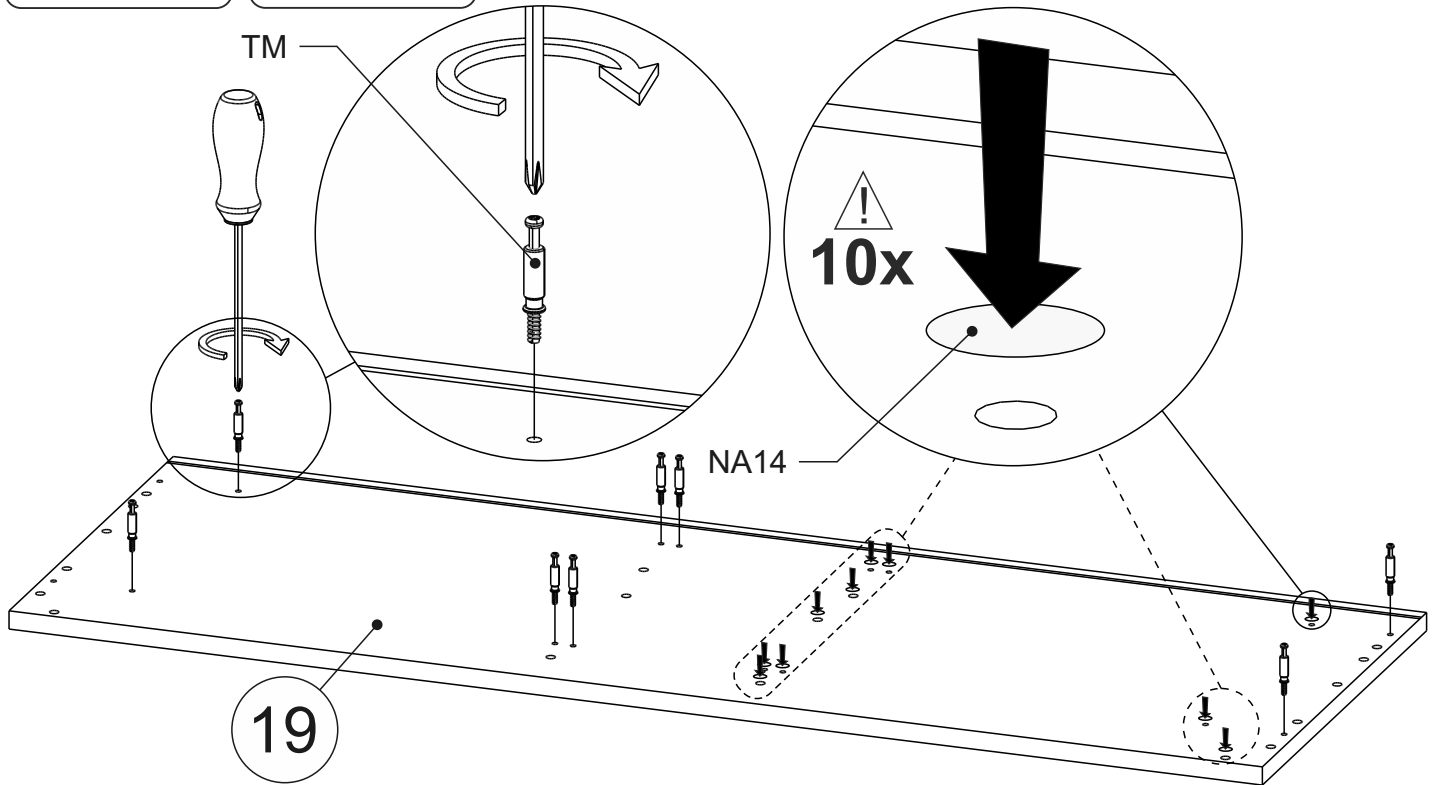
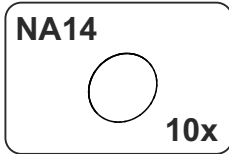
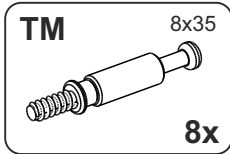
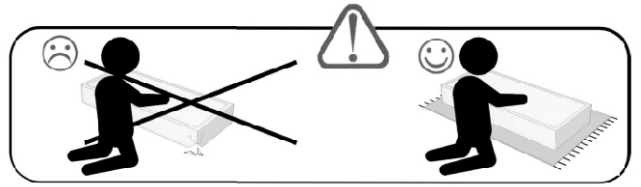

25B

RU Потребуется для сборки:
EN Required for assembly:

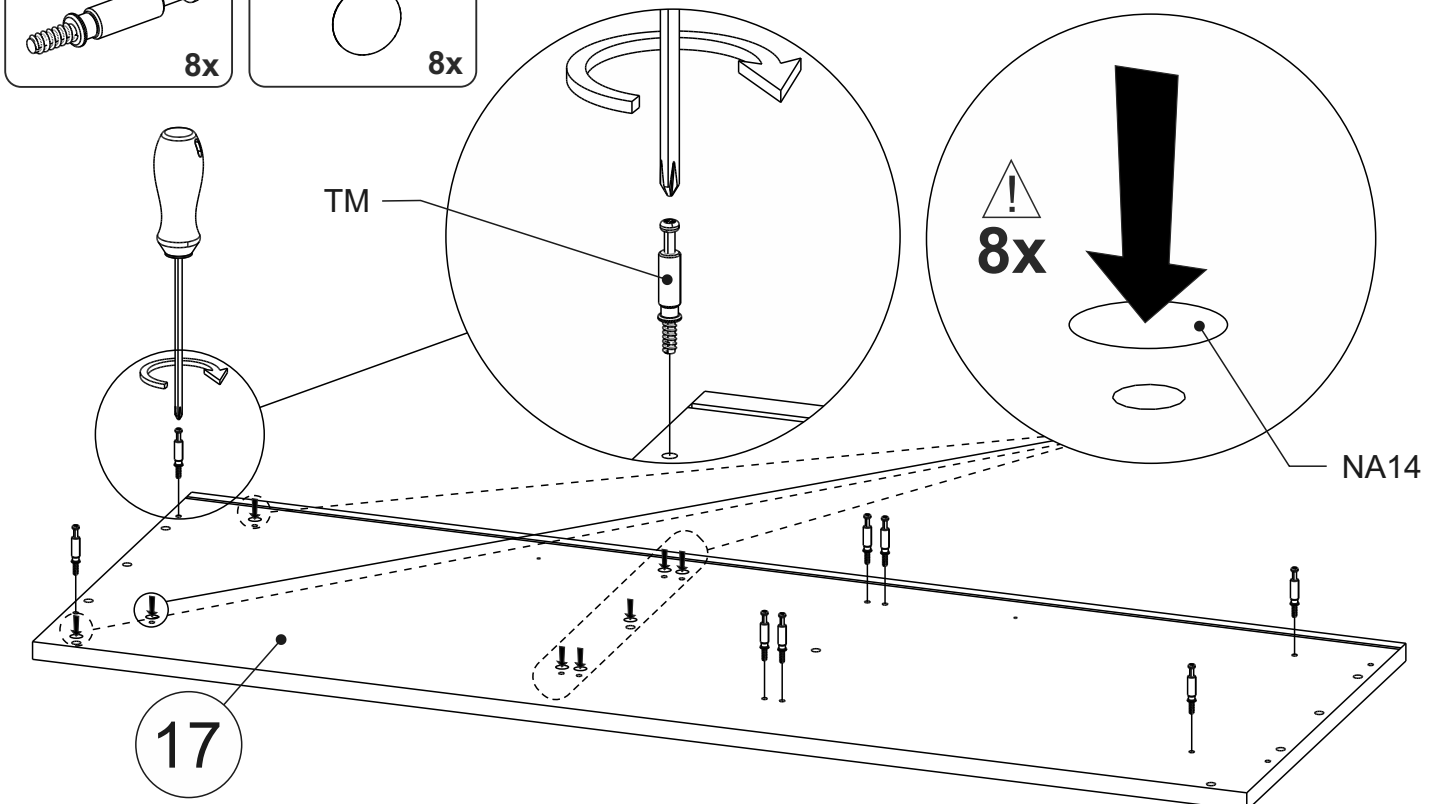
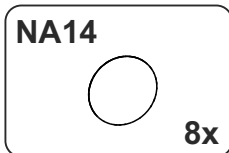
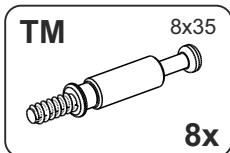
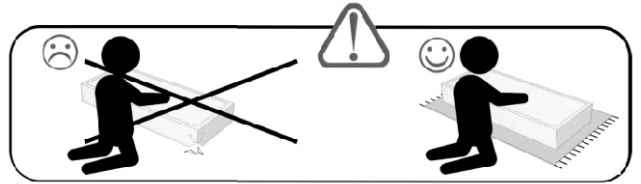

26B

RU Потребуется для сборки:
EN Required for assembly:

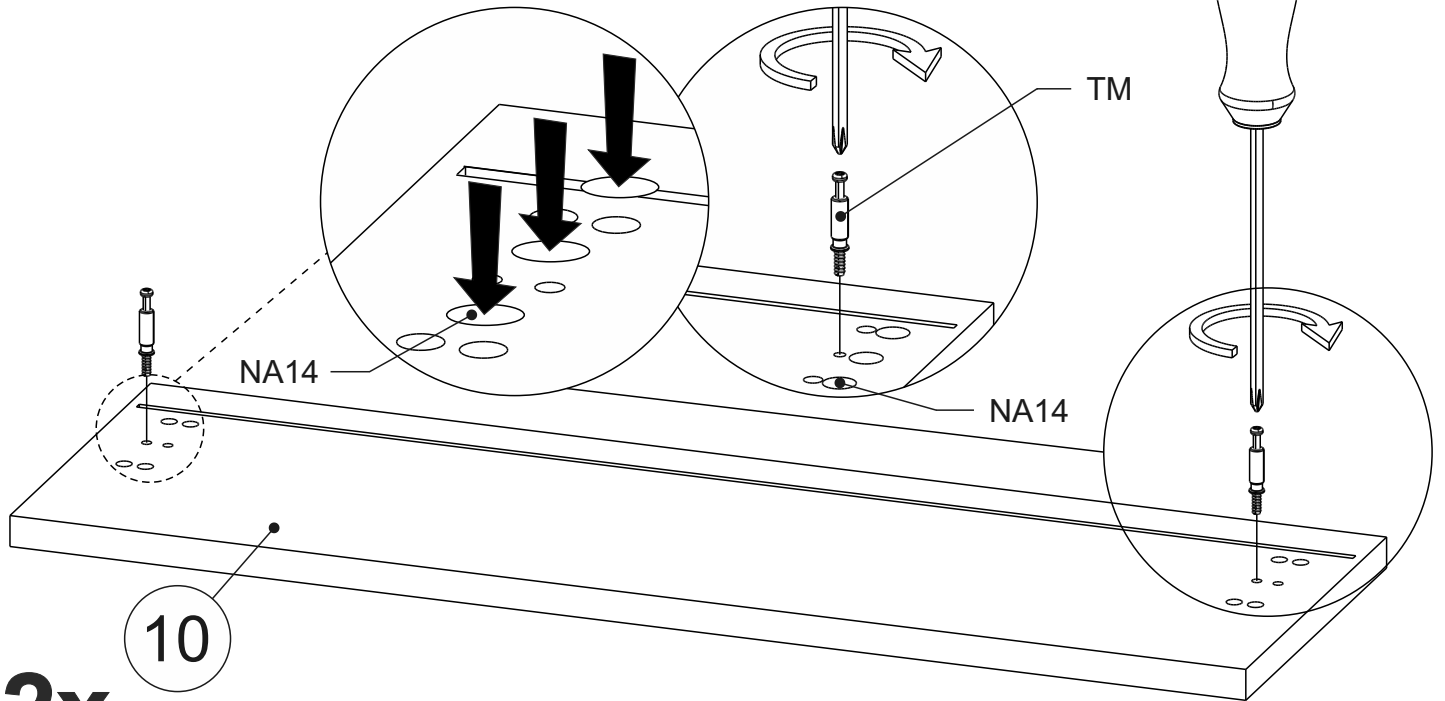
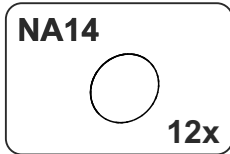
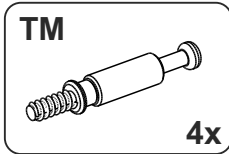
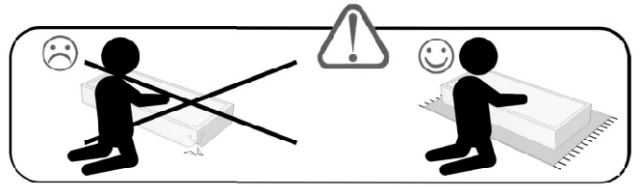

2x

27B

RU Потребуется для сборки:
EN Required for assembly:

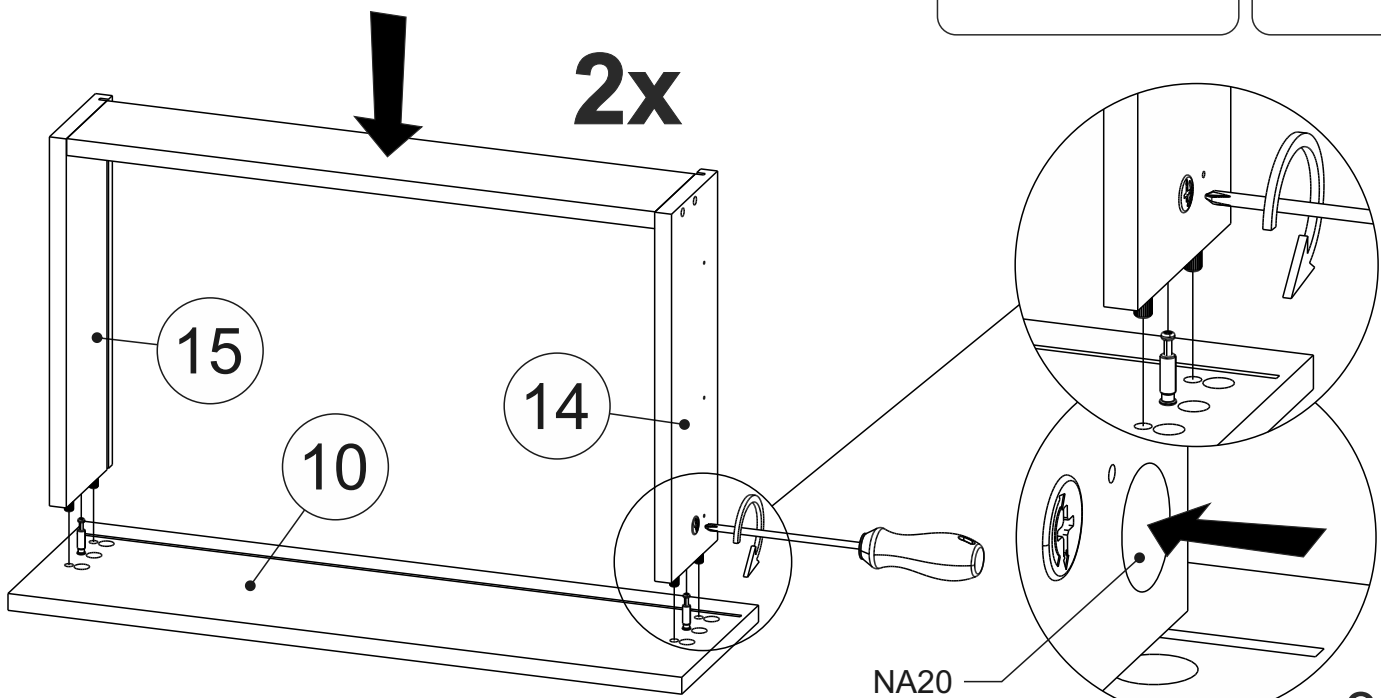
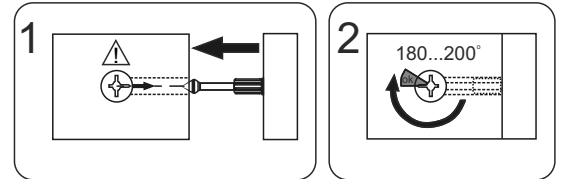
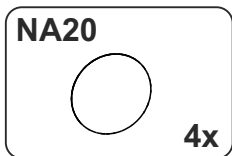
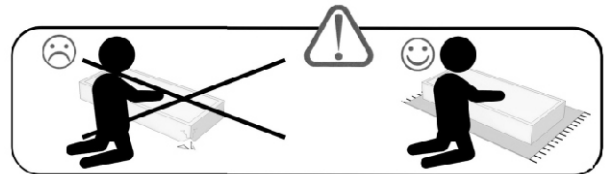

28B

RU Потребуется для сборки:
EN Required for assembly:

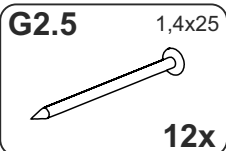
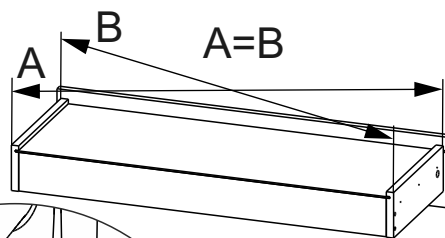

30

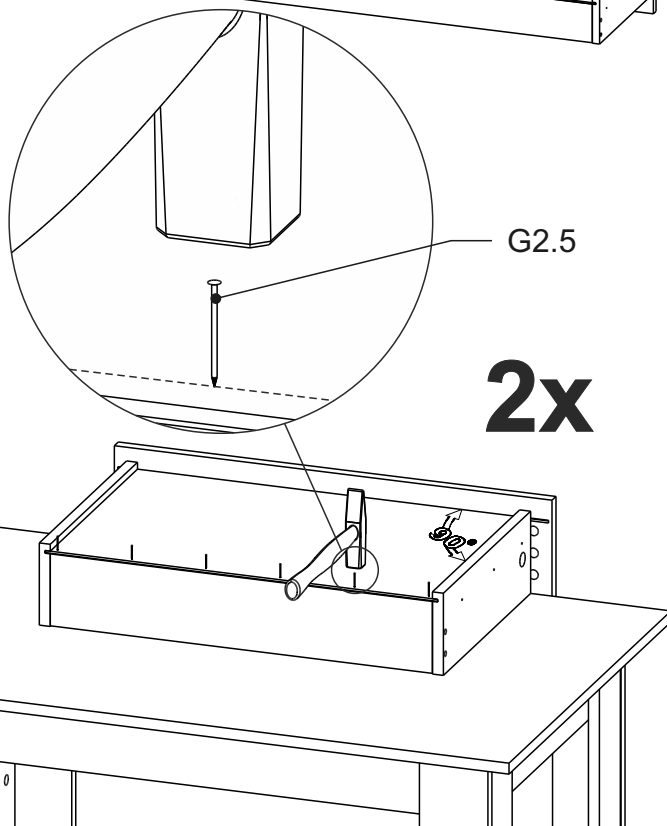
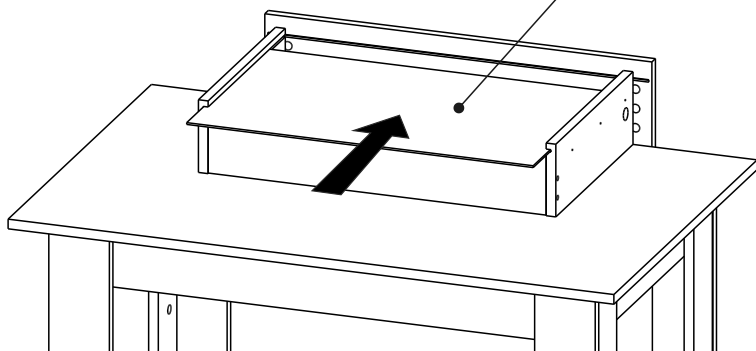

2x

2x

29B

RU Потребуется для сборки:
EN Required for assembly:

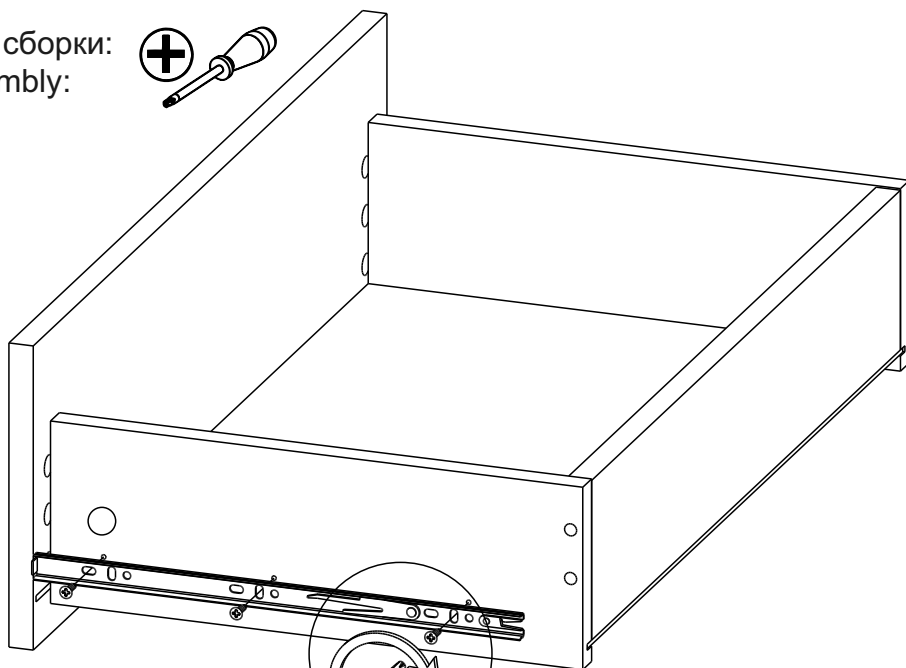
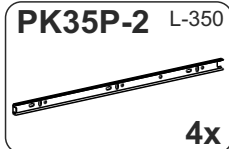
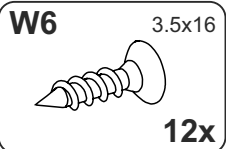

2x

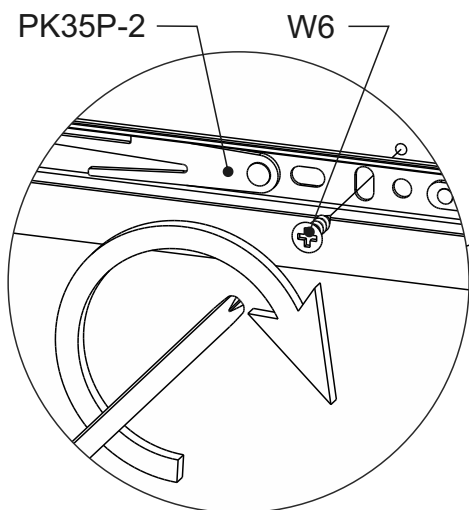

30B

RU Потребуется для сборки:
EN Required for assembly:

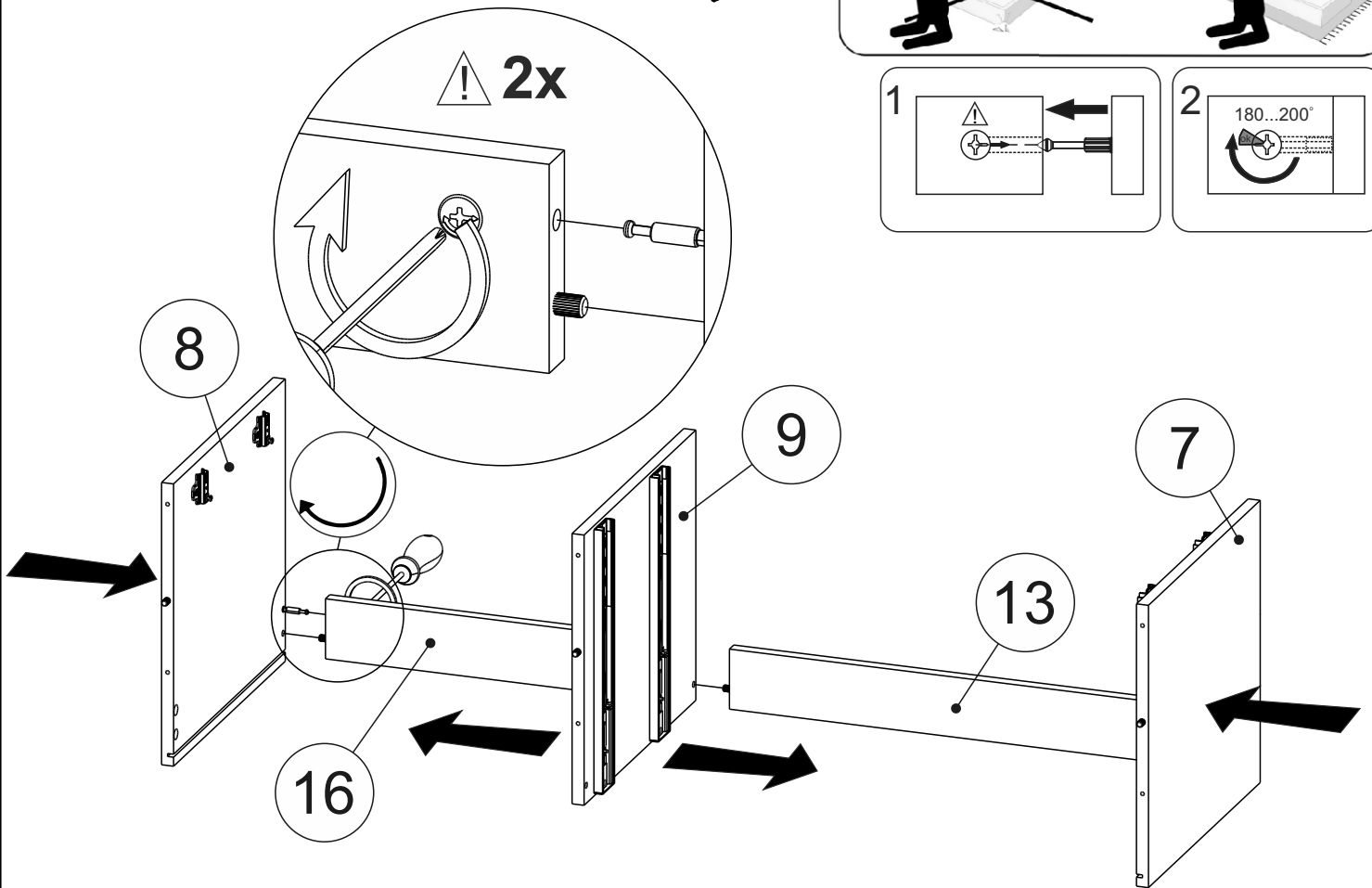
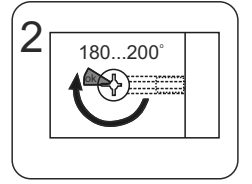
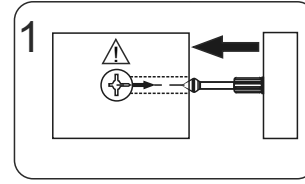
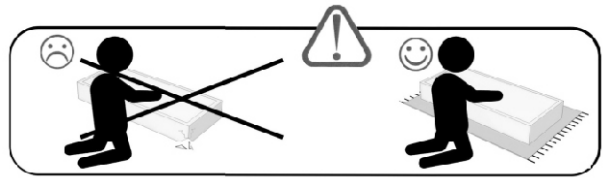

31B

RU Потребуется для сборки:
EN Required for assembly:

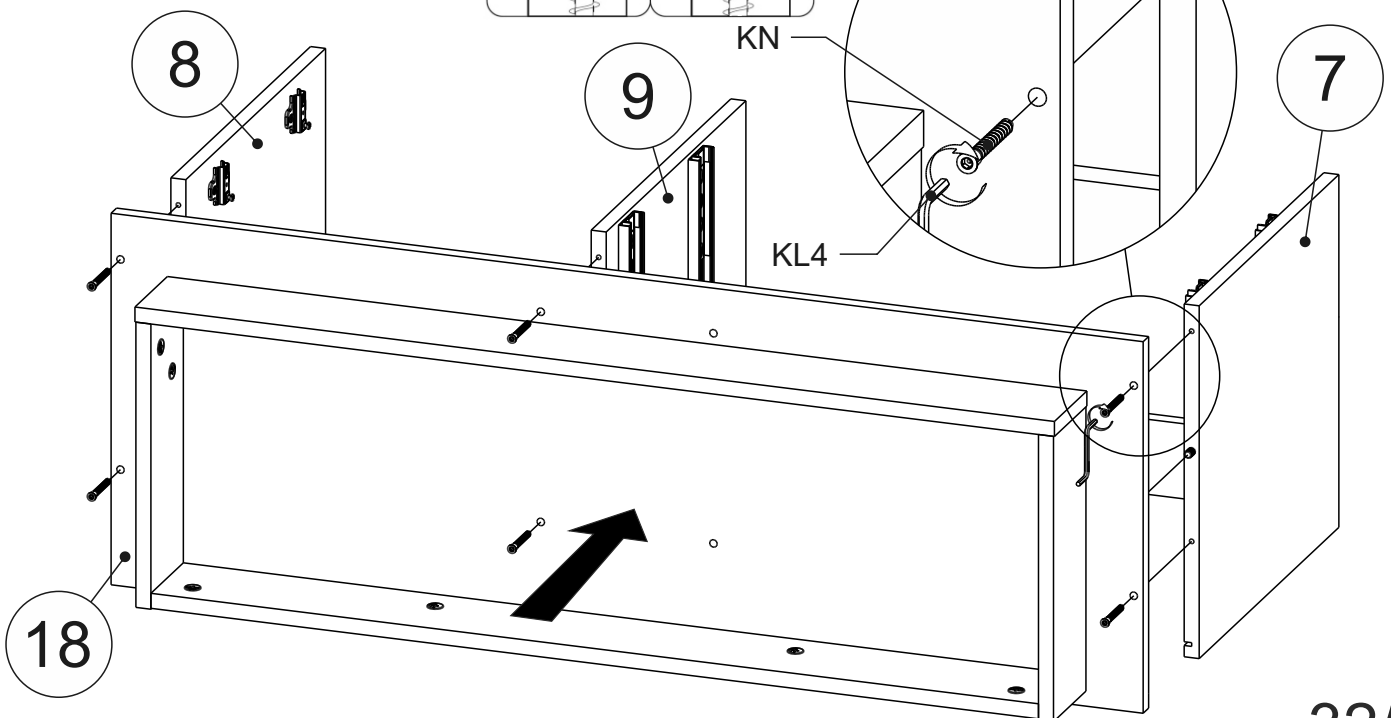
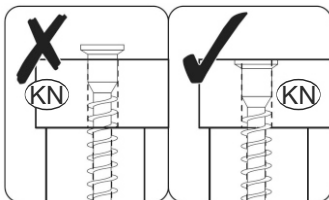
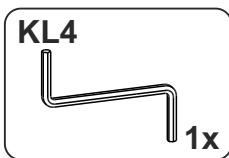
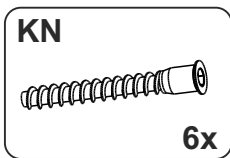
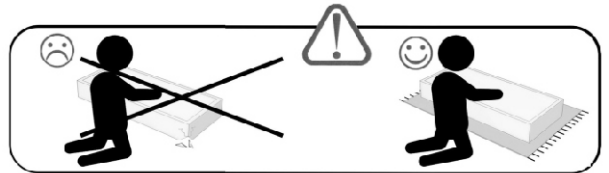

32B

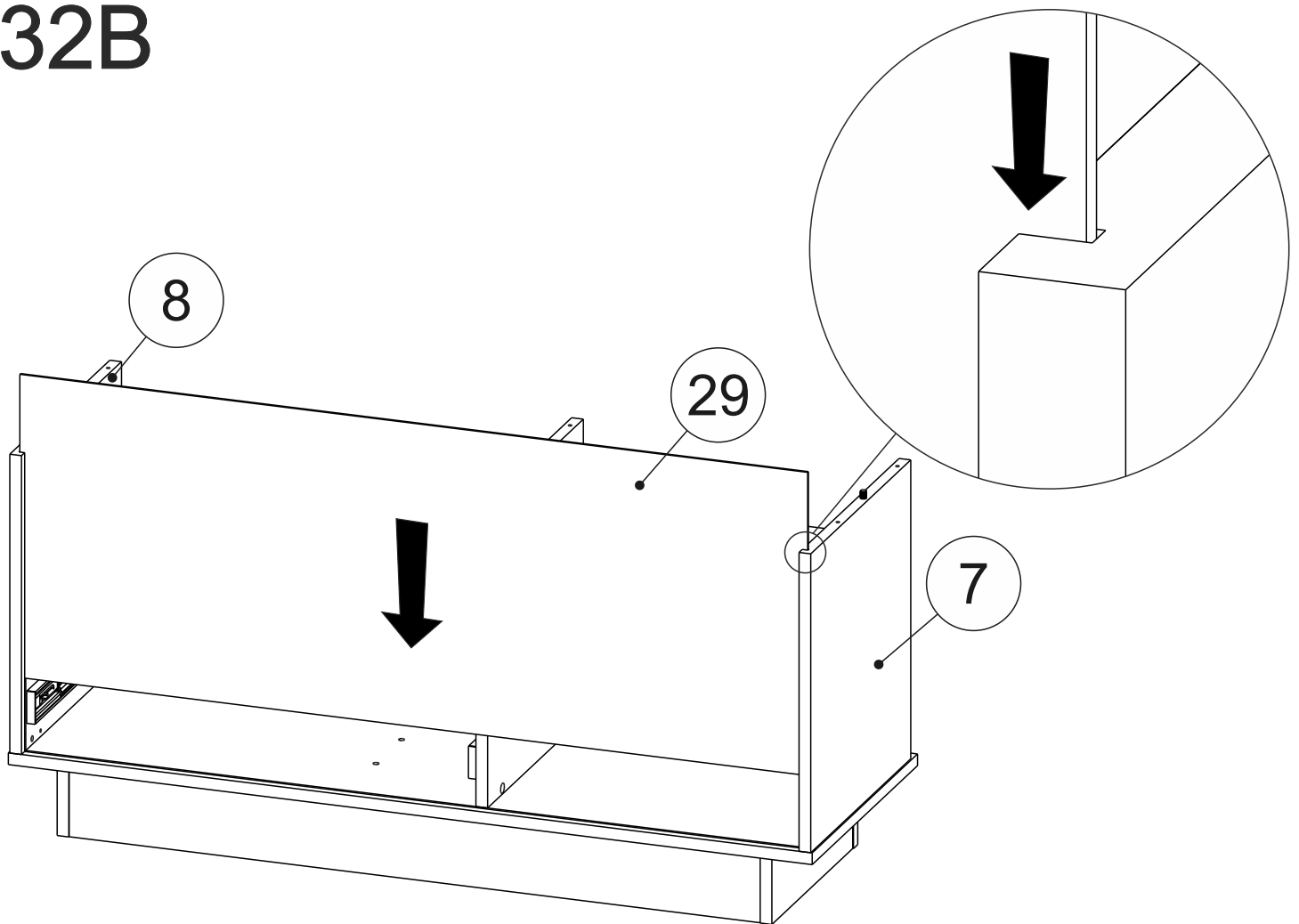

33B

RU Потребуется для сборки:
EN Required for assembly:

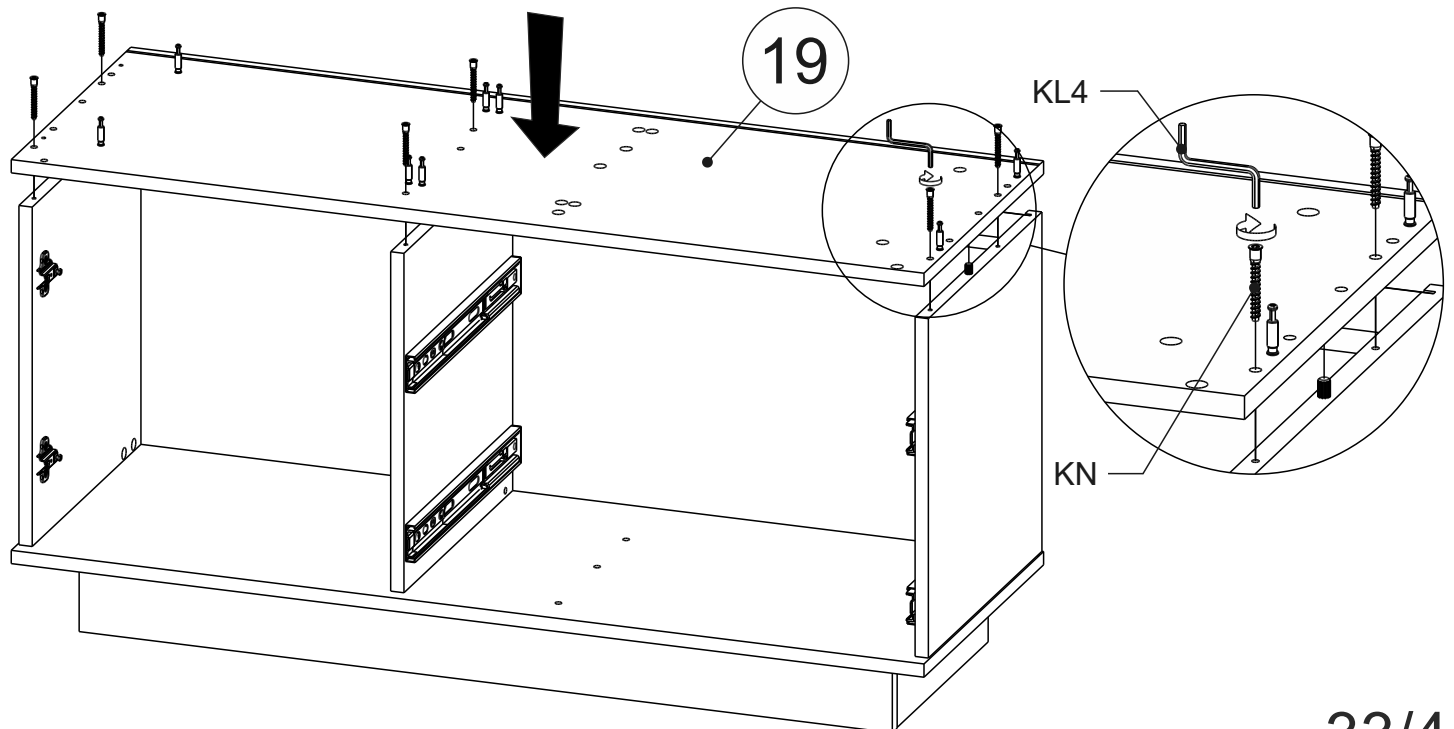
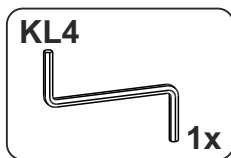
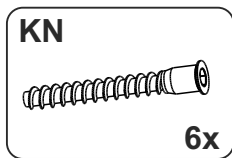
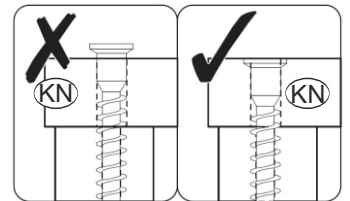

34B

RU Потребуется для сборки:
EN Required for assembly:

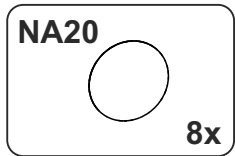
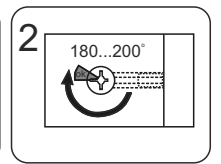
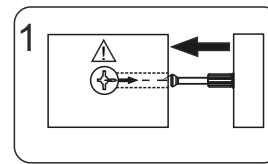

2

11

20

21

4

3

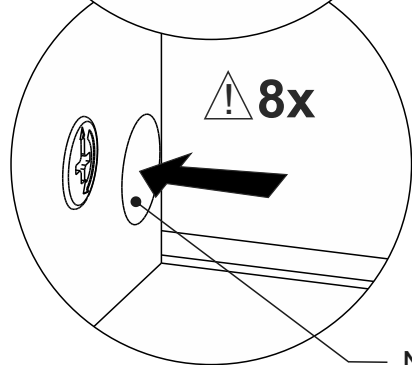
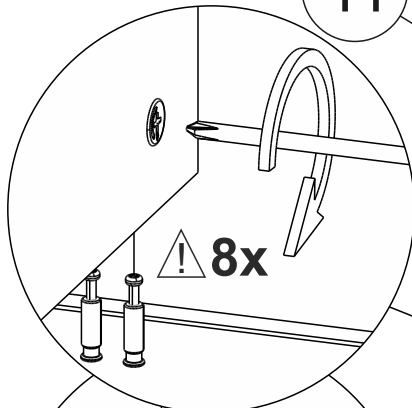

NA20

35B

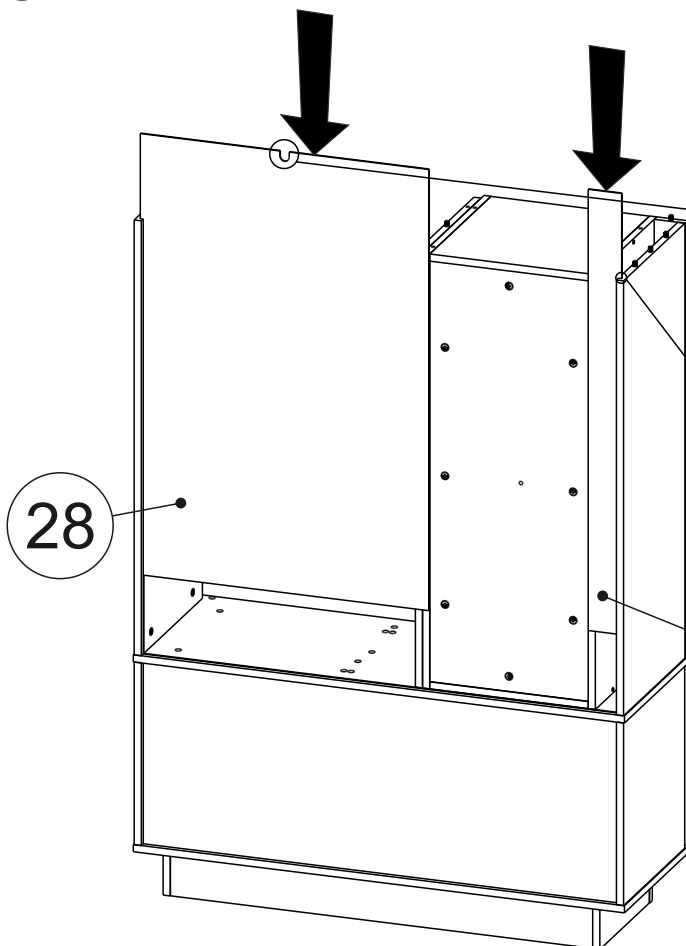

28

31

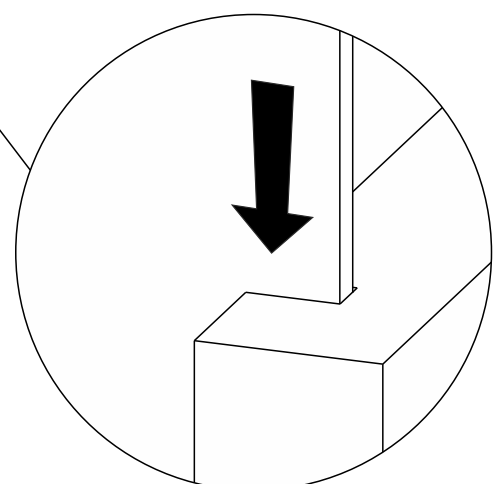
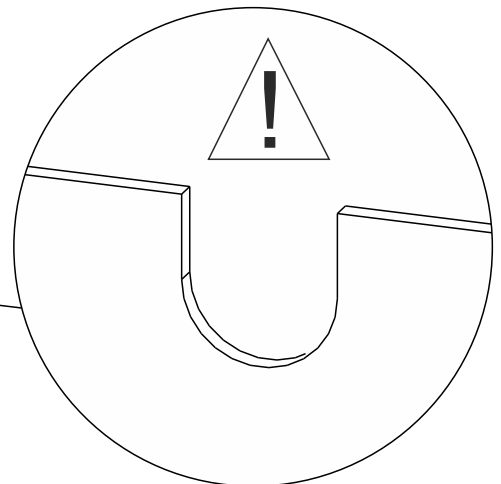

36B

RU Потребуется для сборки:
EN Required for assembly:

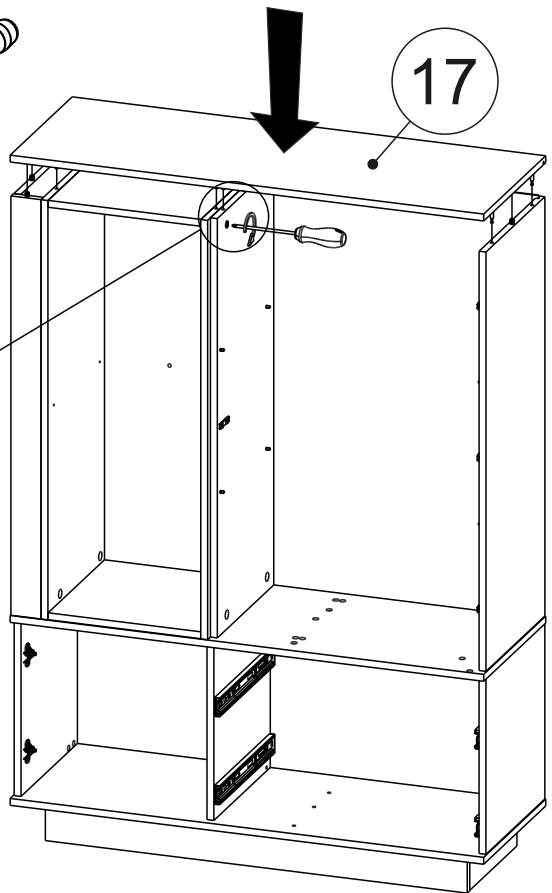
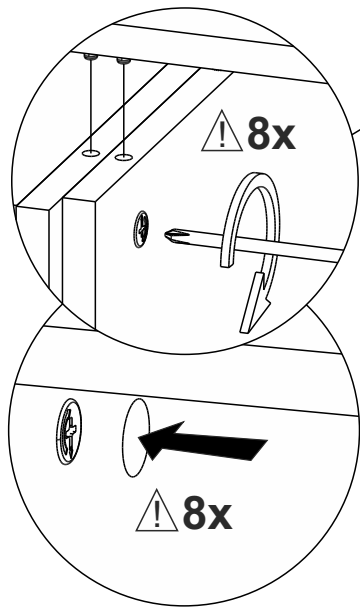
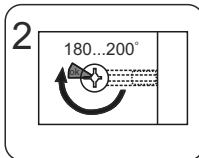
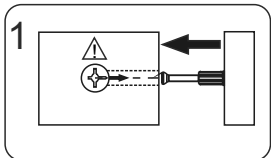
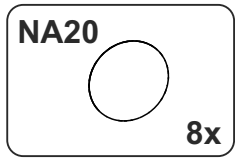

37B

RU Потребуется для сборки:
EN Required for assembly:

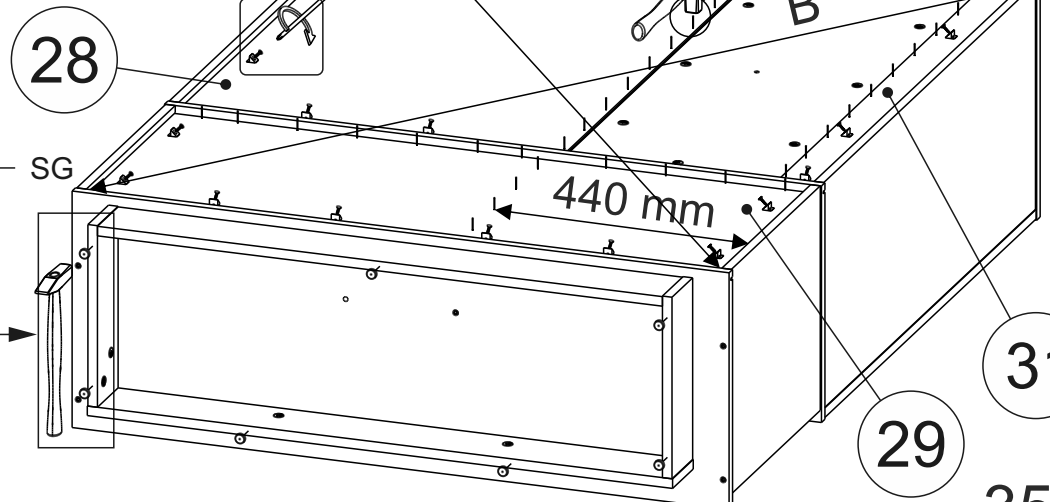
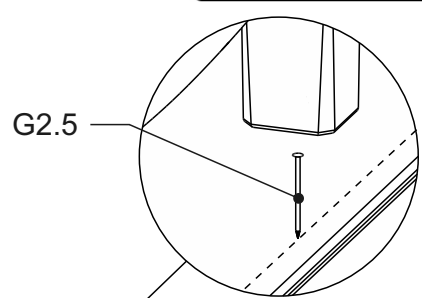
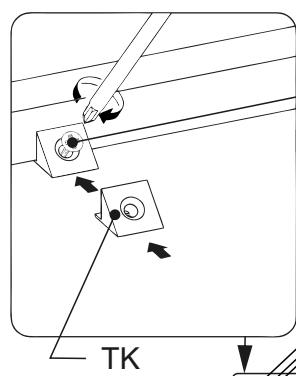
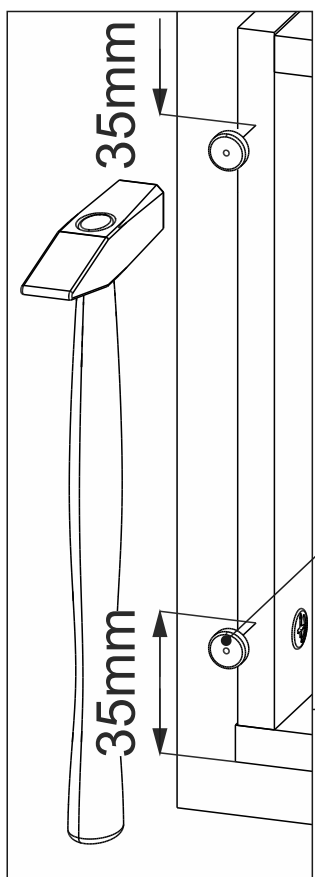
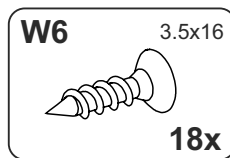
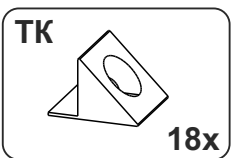
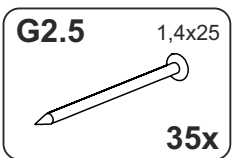
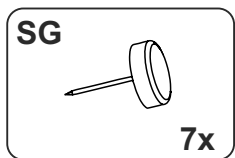
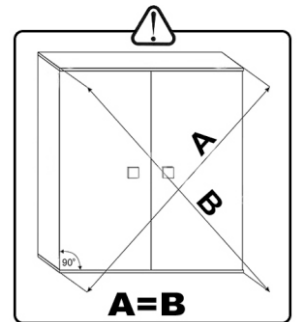

38B

RU Потребуется для сборки:
EN Required for assembly:

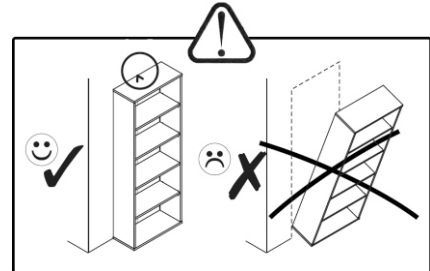
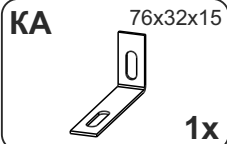
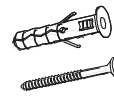

334mm

1500mm

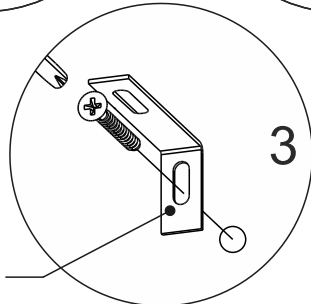
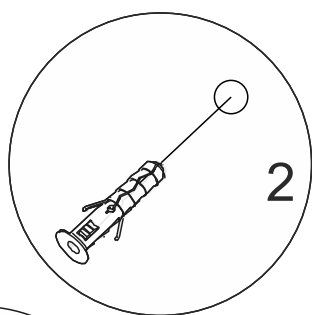
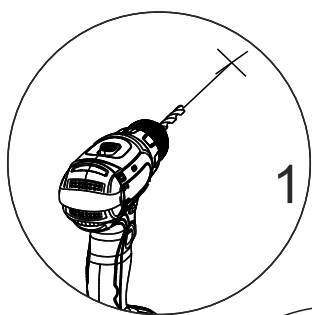
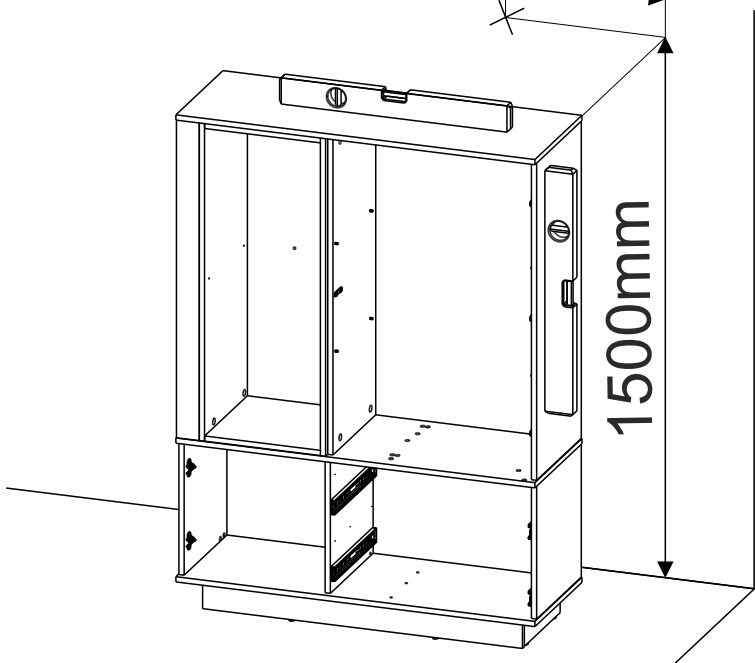

39B

RU Потребуется для сборки:
EN Required for assembly:

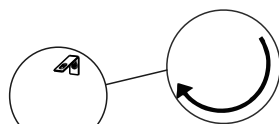
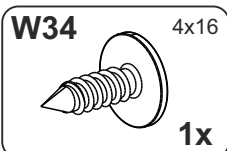

W34

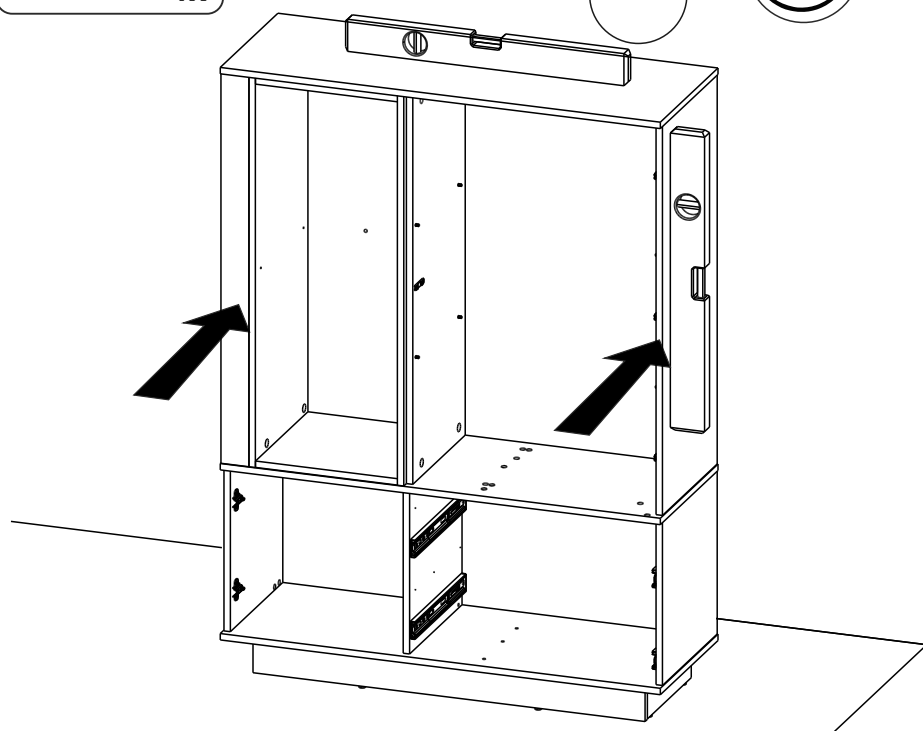
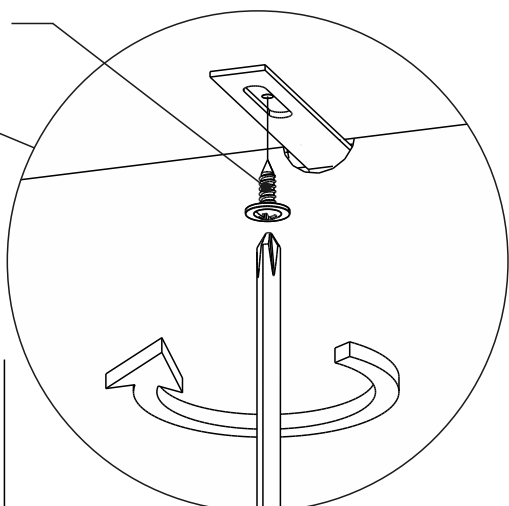

40B

RU Потребуется для сборки:
EN Required for assembly:

MV09



4x

PB2(1)

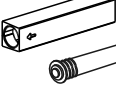

PB2(2)



2x

20

21

4

PB2(1)

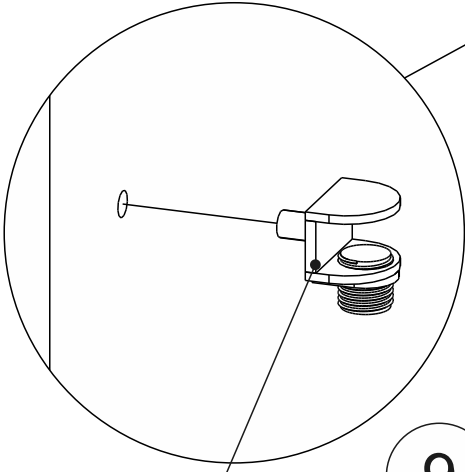
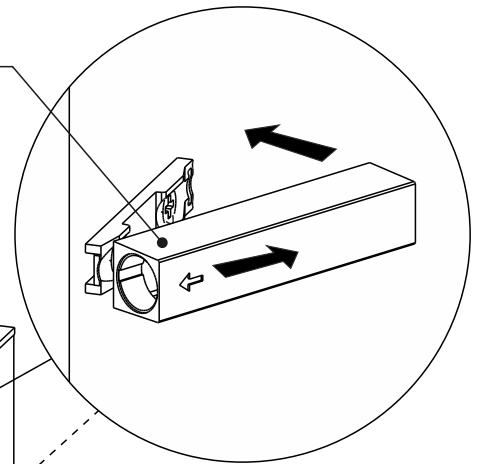

MV09

9

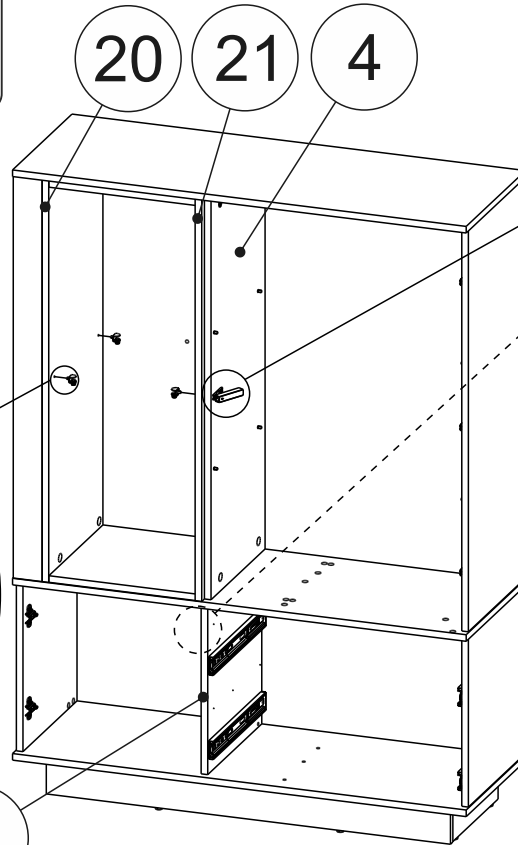

II

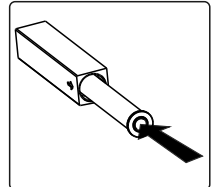

III

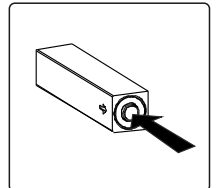

IV

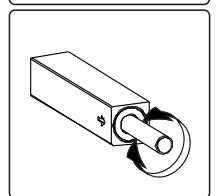

41B

RU Потребуется для сборки:
EN Required for assembly:

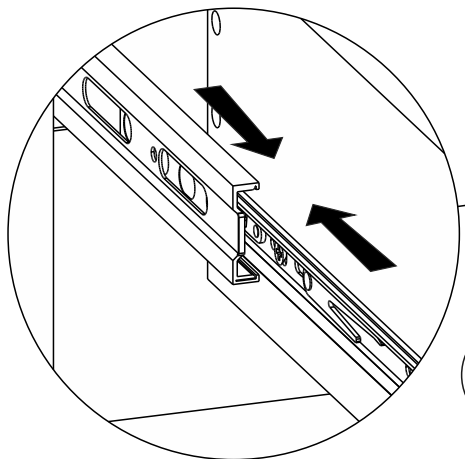
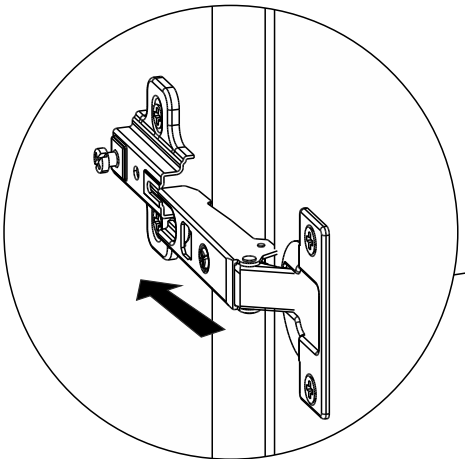

6

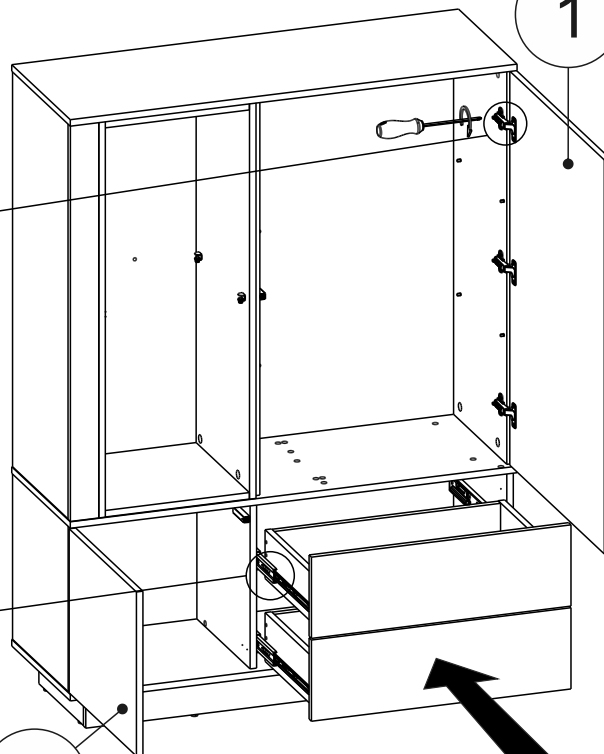

1

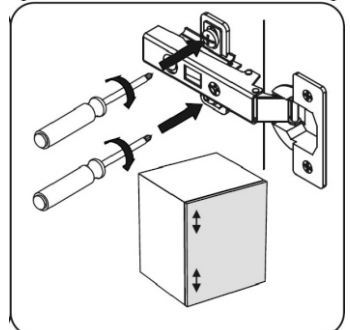
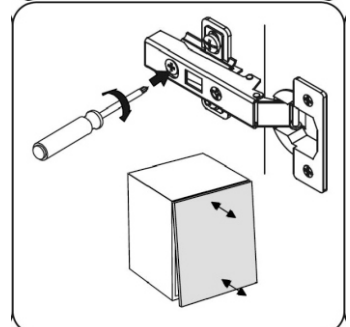
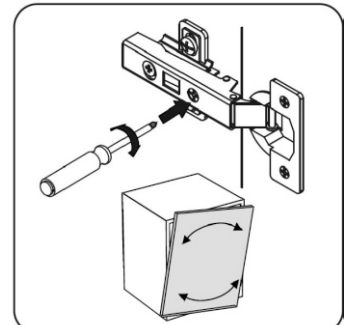

42B

RU Потребуется для сборки:
EN Required for assembly:



PB2(5)



PB2(4)

2x

1

PB2(5)

PB2(4)

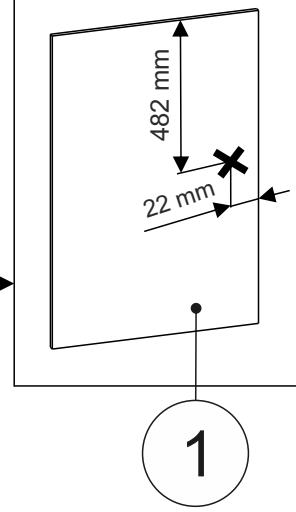
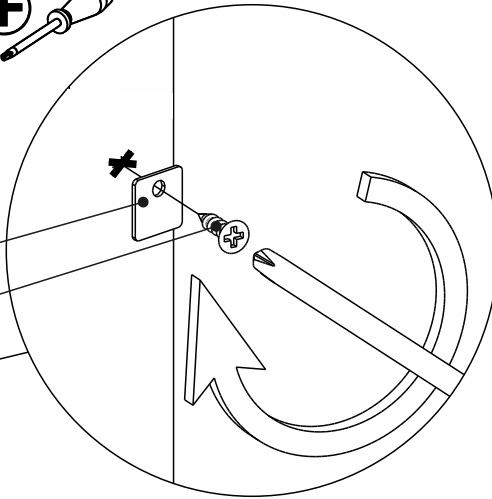
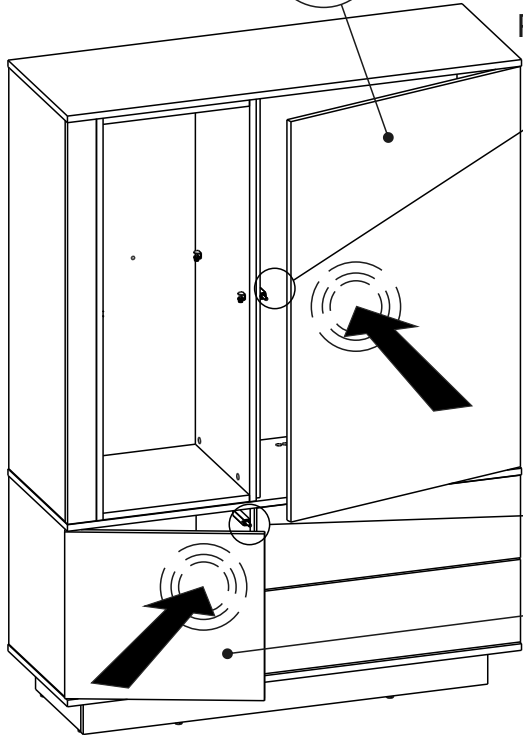

1

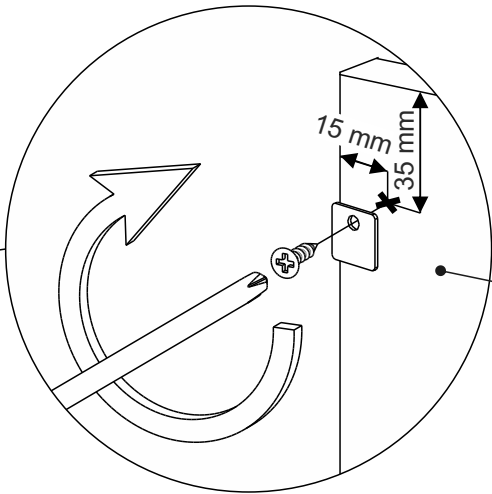

6

43B

RU Потребуется для сборки:
EN Required for assembly:



5

36

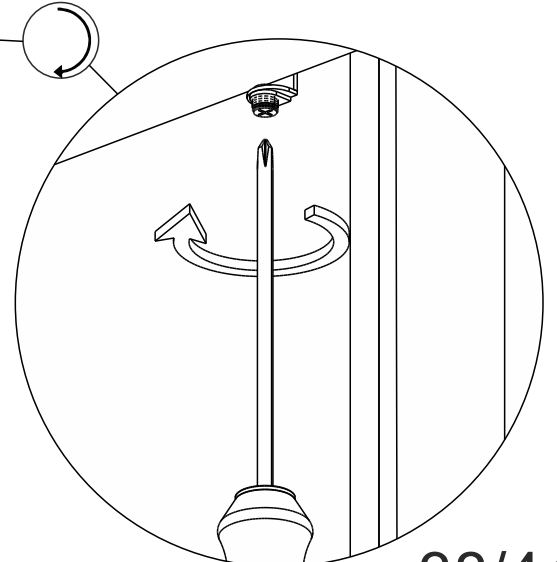
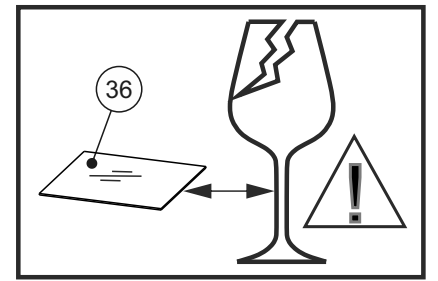
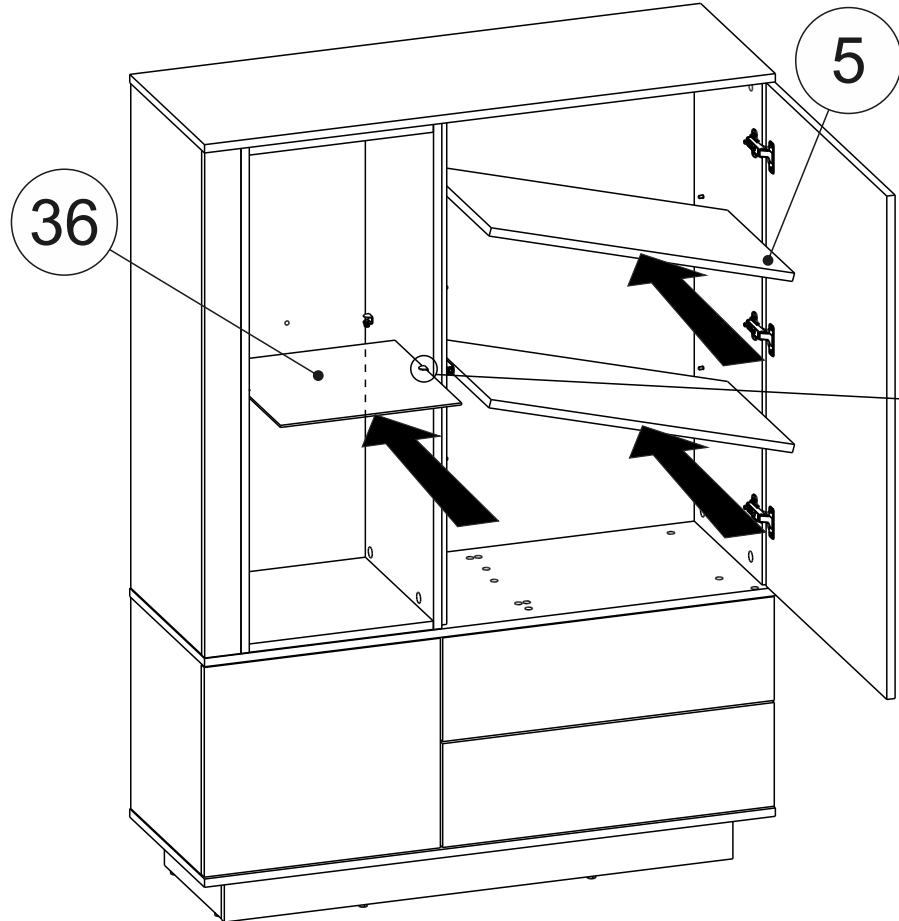

RU Подсветка "QZ-ШК2"

EN Backlight "QZ-SHK2"

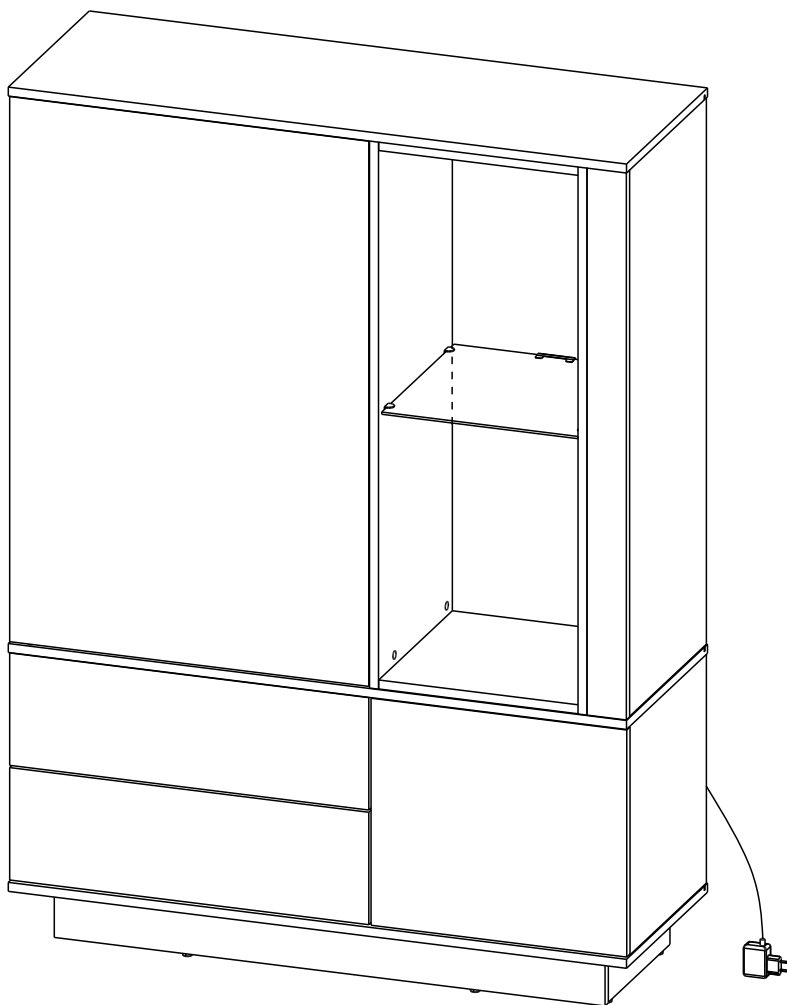
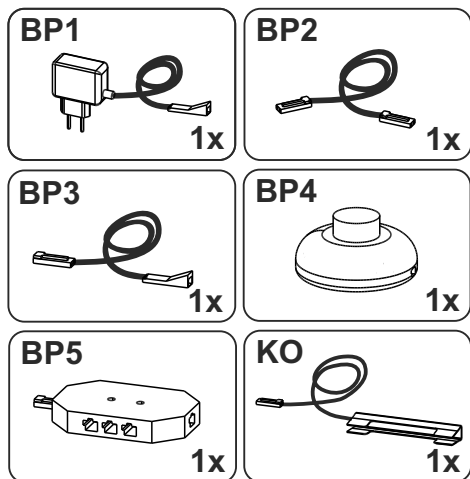

RU Пожалуйста проверьте комплектацию фурнитуры перед сборкой. EN Please check the completeness of the fittings before assembly.

37.1A

RU Потребуется для сборки:

EN Required for assembly:

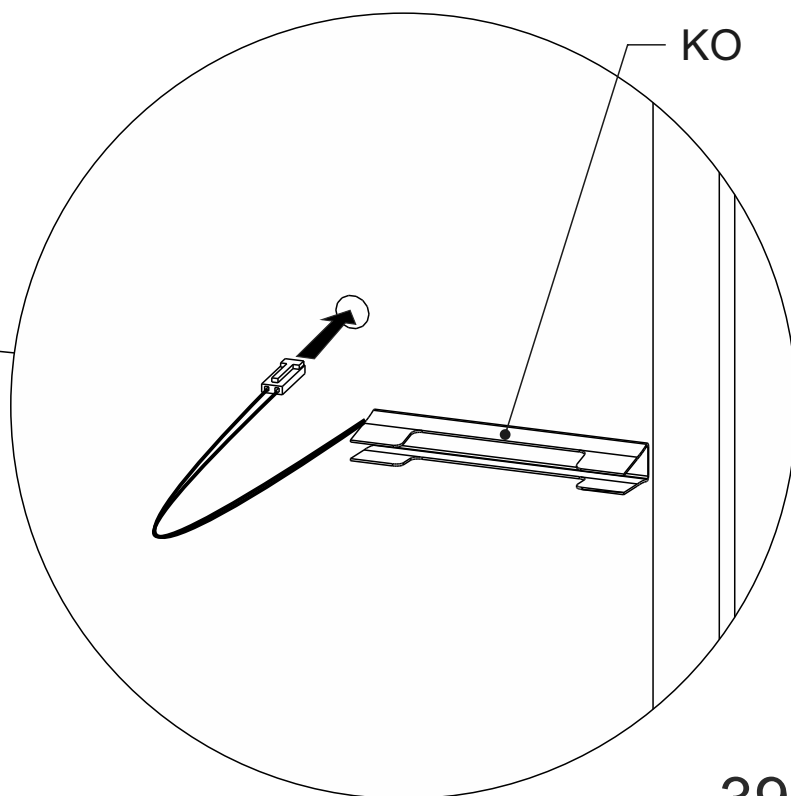
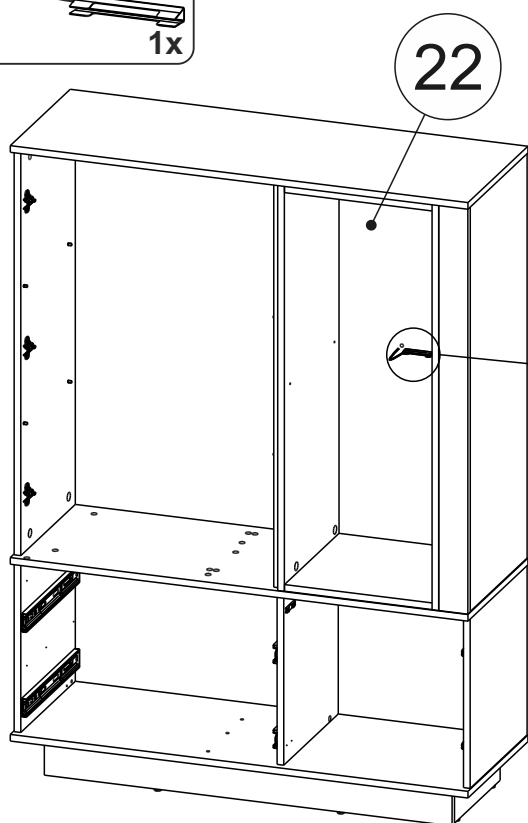
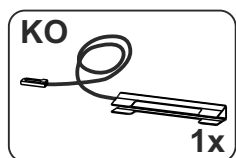

37.2A

RU Потребуется для сборки:
EN Required for assembly:

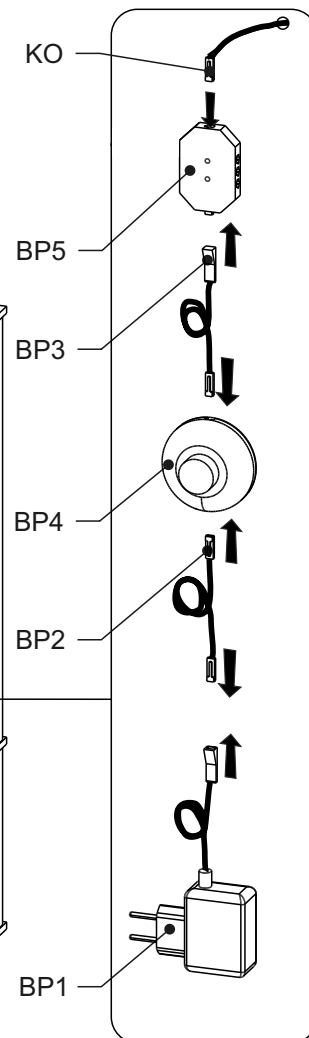
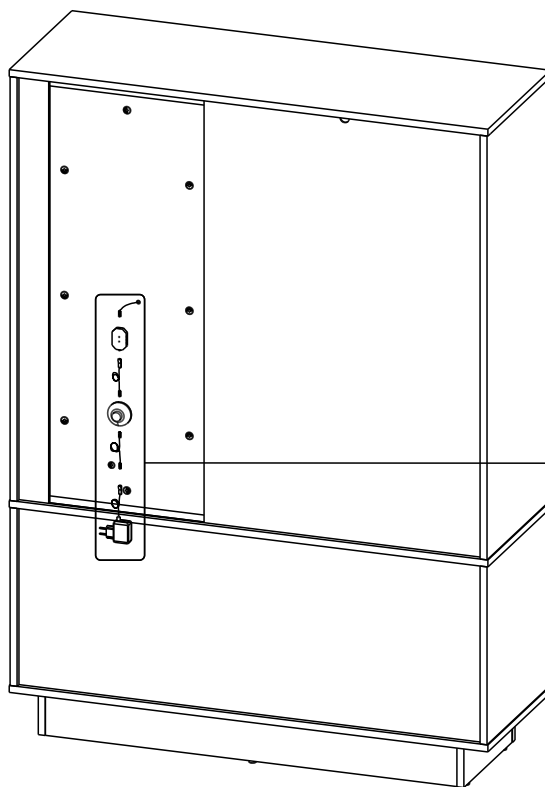
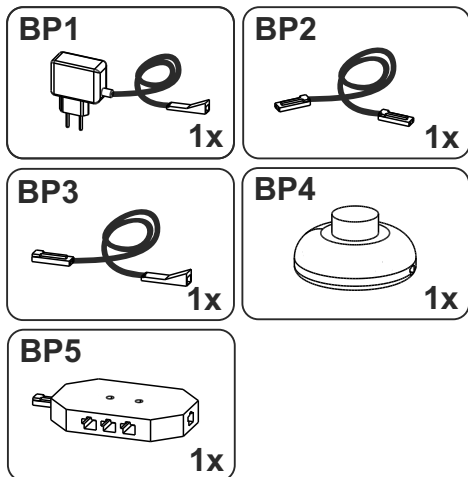

42.1A

RU Потребуется для сборки:
EN Required for assembly:

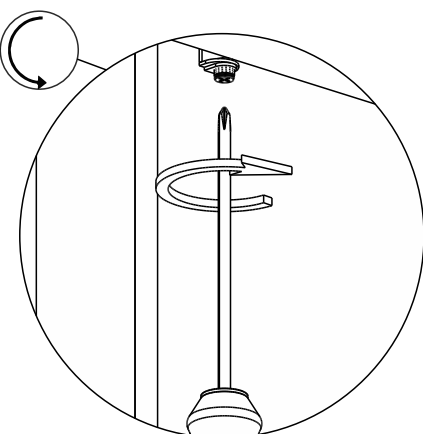
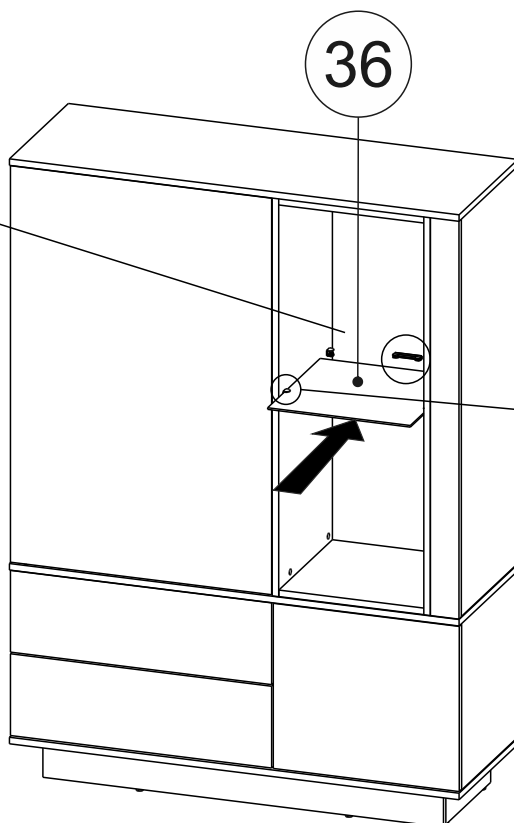
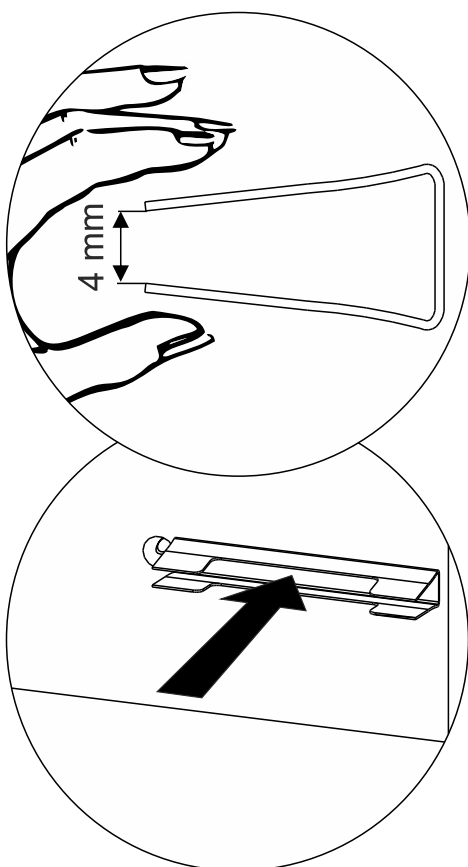
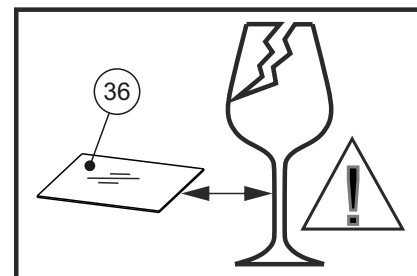

RU Подсветка "QZ-ШК2"

EN Backlight "QZ-SHK2"

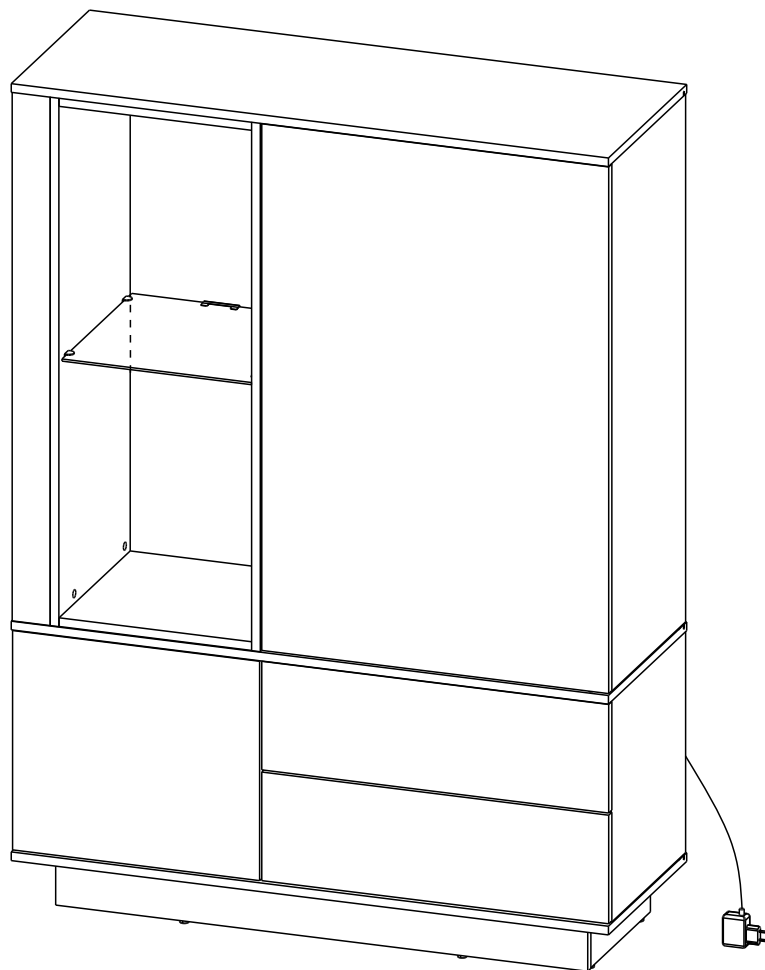
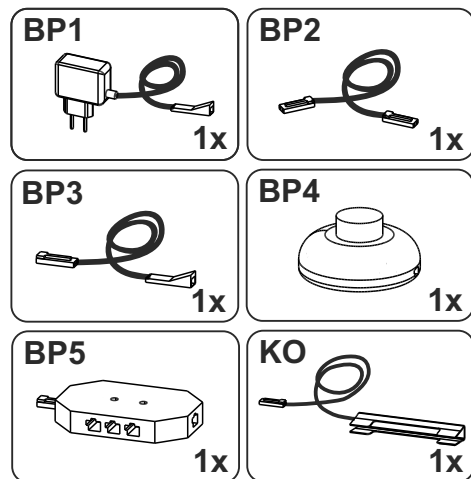

RU Пожалуйста проверьте комплектацию фурнитуры перед сборкой. **EN** Please check the completeness of the fittings before assembly.

37.1B

RU Потребуется для сборки:

EN Required for assembly:

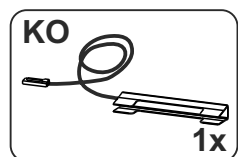

22

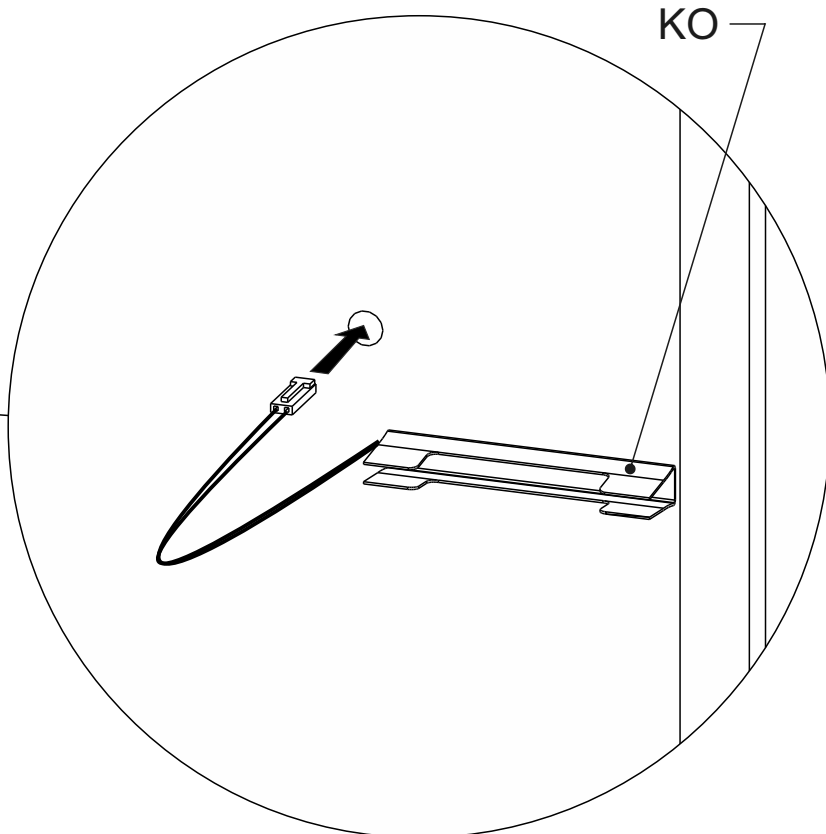
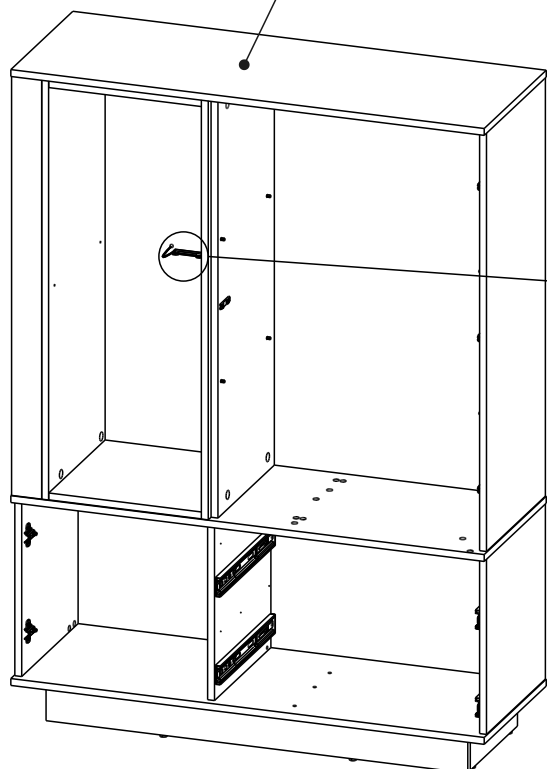

37.2B

RU Потребуется для сборки:
EN Required for assembly:

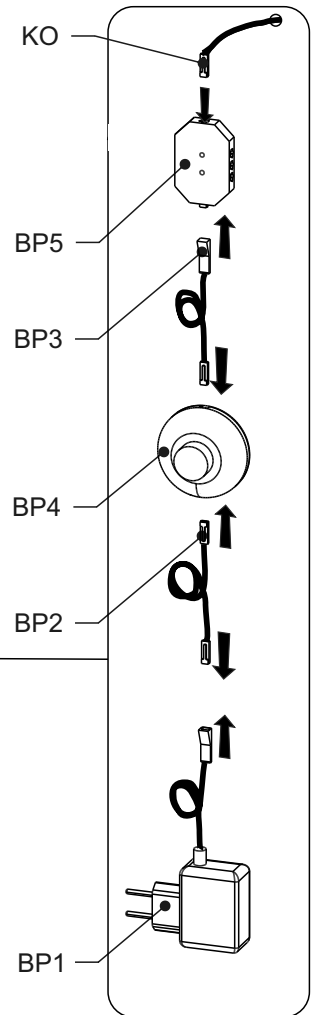
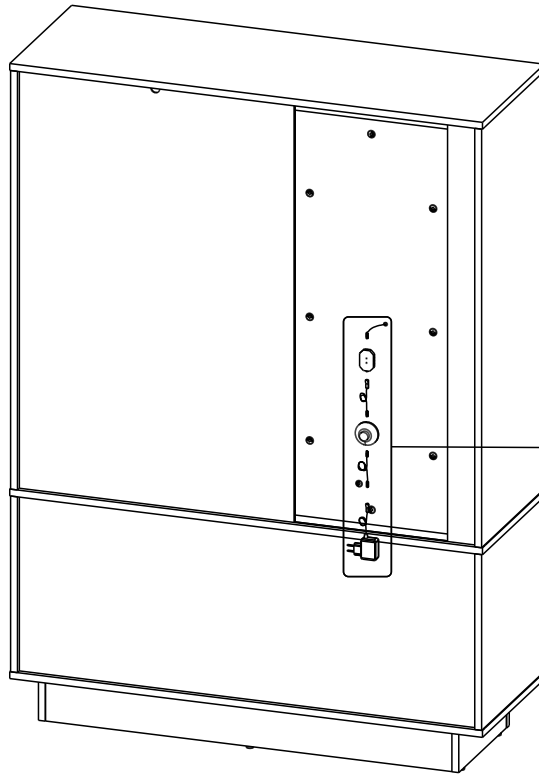
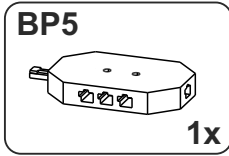
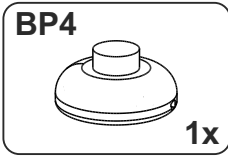
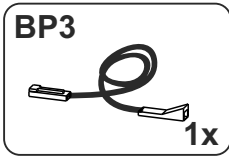
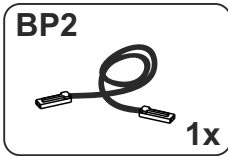
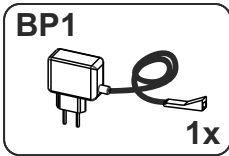

42.1B

RU Потребуется для сборки:
EN Required for assembly:

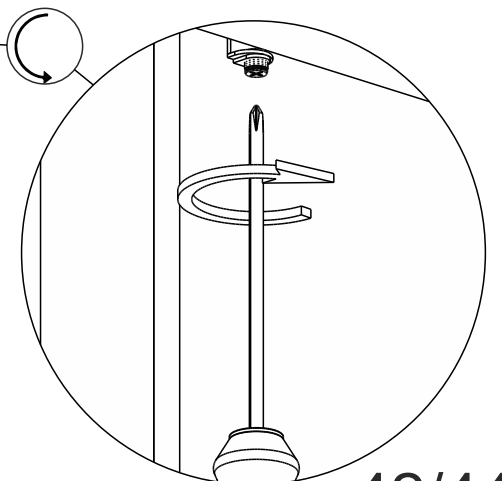
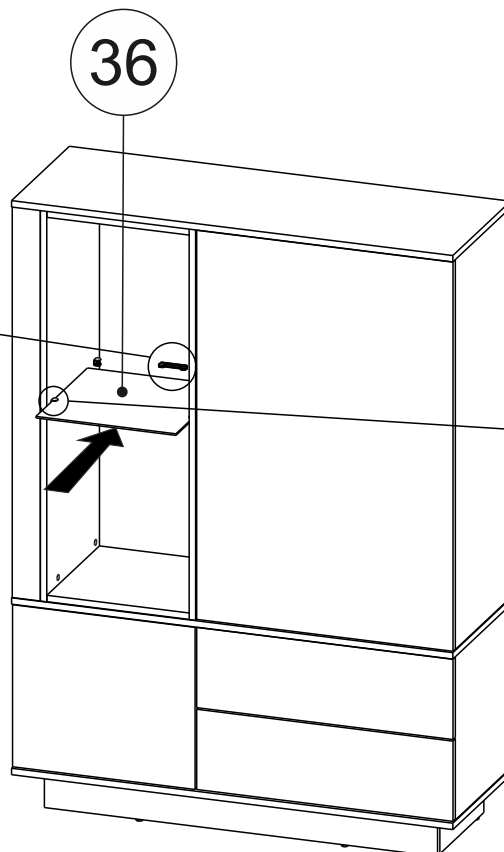
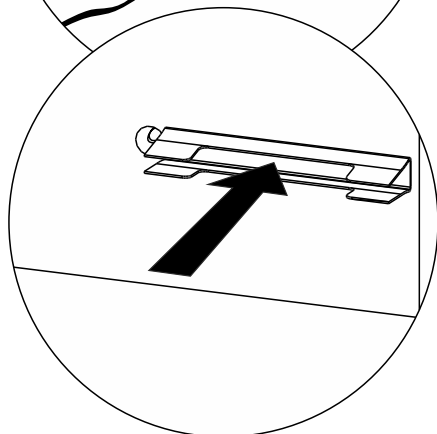
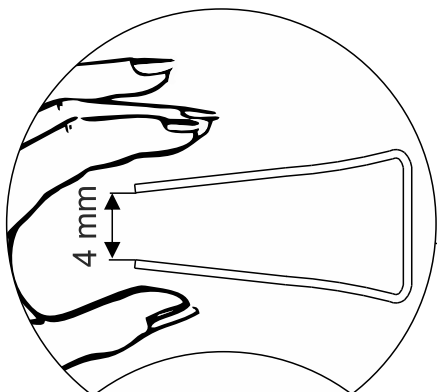
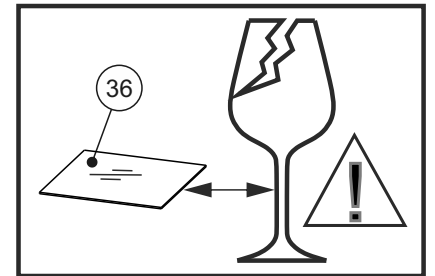

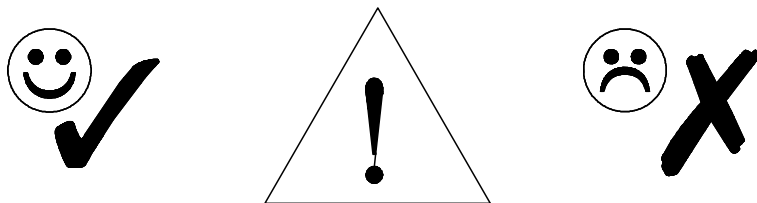

RU

Уважаемый потребитель!

В случае возникновения вопросов по качеству и комплектности приобретённой Вами продукции, в целях быстрого урегулирования проблемы и помощи нам в совершенствовании производственных процессов, просим Вас при обращении в магазин предоставить фотографии:

- поврежденной/бракованной детали
- основной этикетки 100x70мм (находится на поверхности гофроупаковки)
- складской этикетки 50x40мм (находится на поверхности гофроупаковки)
- печати упаковщика (находится рядом со складской этикеткой на гофроупаковке)
- печати фурнитуры (находится на пакете или коробке фурнитуры)
- этикетки обработки (этикетка похожая на ценник, нанесена непосредственно на деталь)

Благодарим Вас за содействие!

EN

Dear customer!

If you have any questions about the quality and completeness of the products you purchased, in order to quickly define and resolve the problem and help us improve production processes, we ask you to provide photos when contacting the store:

- damaged/faulty part
- main label 100x70mm (located on the surface of the packaging)
- warehouse label 50x40mm (located on the surface of the packaging)
- stamp of the packer (located next to the warehouse label packaging)
- stamp of fittings manager (located on the package or a packet of fittings)
- processing labels (a label similar to a price tag, applied directly to the part)

Thank you for your assistance!

Приемка мебели

При получении товара не пренебрегайте проверкой приобретенной мебели на предмет ее комплектности и состояния упаковок. Количество упаковок изделия должно соответствовать количеству в сопроводительной документации. Принятие мебели без указания на некомплектность изделия или внешние признаки повреждения упаковки, которые могли быть установлены на этапе приемки, лишают права покупателя в дальнейшем на них ссылаться.

Транспортировка мебели

Рекомендуется пользоваться услугами по перевозке специализированных (имеющих для этих целей транспортные средства и персонал) лицензированных и сертифицированных в установленном порядке организаций, поскольку в этом случае за сохранность груза отвечает перевозчик. При перевозке стоит учитывать, что мебель и упаковка не является влагостойкой. Дефекты мебельных изделий, возникшие в процессе транспортировки, не подлежат устранению в порядке гарантии.

Сборка мебели

Внимание: сборку должен производить квалифицированный специалист специальным инструментом. Непрофессиональная сборка изделия может стать причиной низкого качества сборки, повреждения продукции и причинения травм.

Перед началом сборки мебели внимательно изучите инструкцию по сборке, проверьте комплектность деталей в каждом пакете. Соблюдайте осторожность при установке шкантов в глухие отверстия деталей; при сильных ударах молотком возможно растрескивание материала. При креплении стекла к дверной рамке при помощи стеклодержателей не прилагайте большие усилия во избежание повреждения стекла.

Внимание! Перед монтажом фасадов, проверьте их качество. Установленные фасады не принимаются в рекламацию по качеству.

Рекомендации по эксплуатации и уходу за мебелью

-Так как мебельные изделия чувствительны к свету, влажности и температуре, рекомендуется избегать продолжительного воздействия одного или нескольких этих факторов, так как это может вызвать преждевременное отслоение облицовочных материалов, коробление и деформацию элементов мебели. Изделия мебели должны быть расположены не ближе 1 метра к источнику тепла (батареи, калориферы, котлы и другие нагревательные приборы). Рекомендуемая температура помещения 10-25 град. С. Не допускайте попадания на изделия мебели горячих предметов (утюги, посуда с кипятком и т.п.) или продолжительного воздействия вызывающих нагревание излучений (свет мощных ламп, незэкранированные микроволновые излучатели и т.д.) Всегда содержите поверхности мебельных изделий в полной сухости.

-Поверхности деталей мебели необходимо протирать сухой мягкой тканью (фланель, сукно, плюш, миткаль). Уход за рабочими поверхностями (столешницы, мойки и т.п.), как правило, должен осуществляться мягкой влажной тканью, возможно, с применением специально предназначенных для этих целей специальных моющих или чистящих средств. Ни в коем случае не допускайте попадания на мебельные изделия воды и агрессивных жидкостей (кислот, щелочей, масел, растворителей).

-Все тяжести следует размещать внутри шкафов таким образом, чтобы добиться равномерного распределения нагрузки по всей имеющейся площади и обеспечить необходимое равновесие.

-После определенного срока эксплуатации некоторые механические части (петли, конфирматы, винты, шурупы) могут утрачивать свою первоначальную регулировку, выполненную во время сборки изделий. Это может выражаться в скрипе, затруднении открывания дверей или выдвижных ящиков и т. д. Поэтому при эксплуатации бытовой мебели не следует прилагать чрезмерных усилий для открывания дверей, выдвижных ящиков и других подвижных частей. Их надлежащая работа обеспечивается путем своевременной регулировки петель либо смазки направляющих парафином или аналогичным по своим качествам средством. При ослаблении узлов резьбовых соединений их необходимо периодически подтягивать.

Несоблюдение вышеизложенных условий и рекомендаций, повлекшее возникновение дефектов и недостатков мебели, является основанием утраты права на гарантийное обслуживание.

Претензии по качеству и комплектности мебели должны предъявляться покупателем непосредственно в магазин, в котором была приобретена мебель, с обязательным приложением товарного чека.

Гарантийный срок эксплуатации - 24 месяца.

Furniture receipt

In the process of receiving the furniture, do not neglect checking the furniture for its completeness and visual quality. The amount of packages must be equal to that mentioned in the accompanying documentation. Check the packaging for signs of damage. Referring to incomplete packaging or visual defects that could be defined at this stage deprives the right of warranty replacement in future.

Transportation of furniture

It is recommended to use specialized services for the transportation of furniture (having vehicles and personnel for these purposes), since in this case the carrier is responsible for the safety of the cargo. It must be taken into account that the furniture and the packaging is not waterproof. Defects in furniture products caused during transportation are not subject to warranty replacement.

Furniture assembly

Attention: a qualified technician with specialized tools must carry out assembly. Unqualified assembly may lead to low quality result, possible product damage and injury. Before starting to assemble the furniture, carefully study the assembly manual, check the completeness of the parts in each package. Be careful when installing dowels in blind holes of parts; strong blows with a hammer may cause cracking of the material. When attaching glass to the door frame using glass holders, do not use excessive force to avoid damage to the glass.

Attention! Before installing the fronts, check their quality. Installed fronts will not be accepted for warranty replacement.

Recommendations for the exploitation and care of furniture

-Since furniture products are sensitive to light, humidity and temperature, it is recommended to avoid prolonged exposure to one or more of these factors, as this can cause premature peeling of front laminate materials, warping and deformation of furniture elements. Furniture items should be located at least 1 meter apart from a heat source (batteries, heaters, boilers and other heating devices). The recommended room temperature is 10-25 degrees. Do not expose furniture items to hot objects (irons, dishes with boiling water, etc.) or prolonged exposure to heat-generating radiation (light from powerful lamps, unshielded microwave radiators, etc.) Always keep the surfaces of furniture items completely dry.

-Surfaces of furniture parts should be wiped with a dry soft cloth (flannel, broadcloth, plush, calico). Maintenance of work surfaces (countertops, sinks, etc.), as a rule, should be carried out with a soft damp cloth, possibly with the use of special detergents or cleaning agents specially designed for these purposes. Under no circumstances should you expose furniture products to water or corrosive liquids (acids, alkalis, oils, solvents).

-All weights should be placed inside the cabinets/ over the shelves in such a way as to achieve an even distribution of the load over the entire available surface and ensure safe balance.

-After a certain period of exploitation, some mechanical parts (hinges, screws and other fittings) may lose their original adjustment made during the assembly. This can result in creaking, difficult opening of doors or drawers, etc. Therefore, when using household furniture, you should not use excessive force to open doors, drawers and other moving parts. Their proper operation is ensured by timely adjustment of the hinges or lubrication of the guides with paraffin or a similar agent.

Defects and deficiencies of the furniture resulting from bad care and failure to comply with the above recommendations will not be fixed/replaced under the warranty terms.

Claims for the quality and completeness of furniture must be submitted by the buyer directly to the store from which the furniture was purchased, with the obligatory attachment of a sales receipt.

The warranty period is 24 months.