

Sandwich Maker with Removable Plates

User's manual

EN



SENCOR®

SSM 9940SS

Translation of the original manual

CONTENTS

IMPORTANT SAFETY INSTRUCTIONS.....	3
DESCRIPTION OF THE SANDWICH MAKER.....	7
BEFORE FIRST USE.....	7
REPLACING BAKING PLATES.....	7
USING THE SANDWICH MAKER.....	7
CLEANING AND MAINTENANCE.....	8
STORAGE.....	8
TECHNICAL SPECIFICATIONS.....	8
TIPS FOR PREPARING DELICIOUS SANDWICHES.....	9
RECIPES - SANDWICHES.....	9
RECIPES - WAFFLES.....	9
INSTRUCTIONS AND INFORMATION REGARDING THE DISPOSAL OF USED PACKAGING MATERIALS.....	10
DISPOSAL OF USED ELECTRICAL AND ELECTRONIC EQUIPMENT.....	10

IMPORTANT SAFETY INSTRUCTIONS

READ CAREFULLY AND STORE FOR FUTURE USE.

- This appliance may be used by children 8 years of age and older and by persons with physical or mental impairments or by inexperienced persons, if they are properly supervised or have been informed about how to use the product in a safe manner and understand the potential dangers.
- Children must not play with the appliance. Cleaning and maintenance performed by the user must not be performed by children unless they are older than 8 years of age and under supervision.
- Children younger than 8 years of age must be kept away from the appliance and its power cord.
- In the event that the power cord is damaged, have it repaired at a professional service centre to prevent causing a dangerous situation. It is forbidden to use the appliance if it has a damaged power cord.

**Attention: Hot surface**

- The temperature of accessible surfaces may be higher if the appliance is in operation. Such surfaces may become hot during use. Do not touch the hot surface. This could cause skin burns. Use the handle to open and close the appliance.
- This appliance is not designed to be controlled using a programmed device, external timer switch or remote control.
- Before connecting the appliance to a power socket, check that the technical specifications on the appliance's rating label match the electrical voltage in the socket.

Sandwich Maker with Removable Plates

SSM 9940SS

- Connect the appliance only to a properly grounded socket.
- The appliance is designed for household use only. Do not use it for commercial purposes.
- Do not use the appliance in industrial surroundings or outdoors.
- Do not use the appliance for any other purposes than those intended.
- Do not place the appliance on or near an electric or gas stove or other sources of heat.
- Do not place the appliance on the edge of a workbench or on unstable surfaces. The appliance must be located on a stable and even surface.
- This appliance is supplied with three pairs of removable baking plates. Only use the same pair of baking plates at any one time. Ensure that the baking plates are properly inserted in the appliance before turning it on.
- After connecting the appliance to a power socket, the baking surface and the outer surface of the appliance heats up. Do not touch the hot surface. To close and open the top baking plate use the thermally insulated handle and for removing the finished meal use a wooden or heat resistant plastic spatula.
- During operation, leave sufficient space around the appliance for air circulation. Do not place any items on to the hot surface of the appliance.
- Food may catch on fire during the cooking process, therefore check the sandwich maker regularly. If you notice smoke, disconnect the power plug from the socket and extinguish the fire.
- Always turn off the appliance and disconnect it from the power socket if you leave it without supervision or if you will not be

Sandwich Maker with Removable Plates

SSM 9940SS

- using it and before changing the baking plates or cleaning it.
- Allow the appliance to fully cool down before changing the baking plates, moving, cleaning or storing it.
- Clean the baking plates after each use, see chapter Cleaning and maintenance.
- To avoid potential injury by electrical shock, do not clean the appliance under running water and do not submerge it in water or any liquid.
- Ensure that the power cord does not come into contact with water or moisture or a heated surface.
- Do not disconnect the appliance from the power socket by pulling on the power cord. This could damage the power cord or the power socket. Disconnect the cord from the power socket by gently pulling the plug of the power cord.
- To avoid the danger of injury by electrical shock, do not repair the appliance yourself or make any adjustments to it. Have all repairs or adjustments of the appliance performed at an authorised service centre. Tampering with the appliance during the warranty period may void the warranty.

Sandwich Maker with Removable Plates

SSM 9940SS

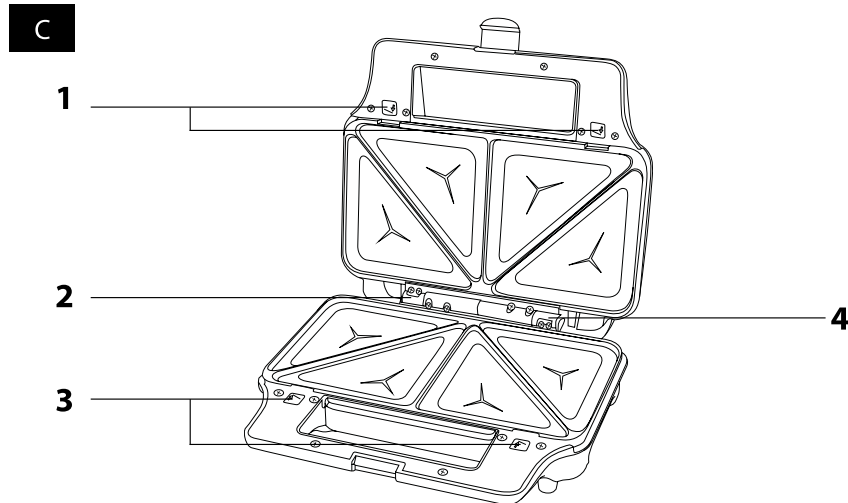
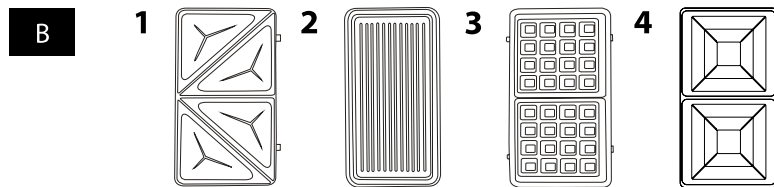
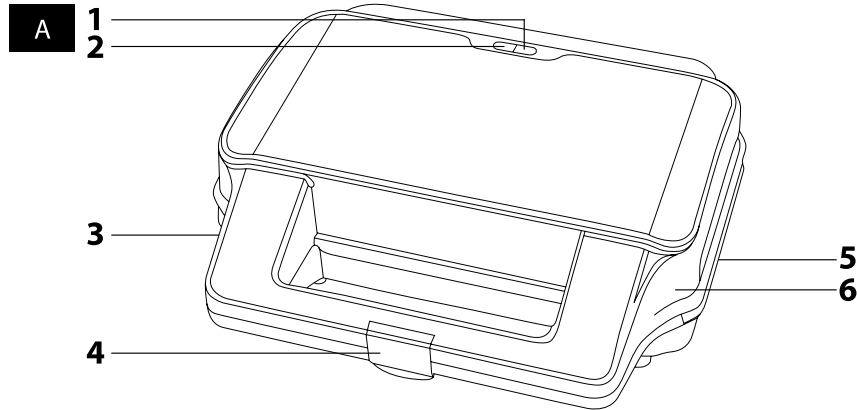

EN-6

Sandwich Maker with Removable Plates

SSM 9940SS

DESCRIPTION OF THE SANDWICH MAKER

A1 Green indicator light Indicates that the baking plates are heating up	A4 Lock To lock and release the handles easily
A2 Red indicator light Indicates connection into the electric power supply	A5 Power cord storage (at the bottom part of the appliance)
A3 Thermally insulated handles	A6 Baking plates with a special non-stick coating
B1 Removable plates for toasting sandwiches	B3 Removable waffle plates
B2 Removable panini plates	B4 Removable plates for toasting sandwiches
C1 Slide locks for securing the top plate	C3 Slide locks for securing the bottom plate
C2 Left hinge	C4 Right hinge

BEFORE FIRST USE

- 1) Remove the Sandwich Maker from the packing material.
- 2) Wipe the removable baking plates **B1**, **B2**, **B3**, **B4** with a wet cloth or sponge and dry completely with a paper towel of dry cloth.
- 3) We recommended you allow the sandwich maker to run empty for 5-7 minutes before first use for each pair of baking plates, so that any odours present are removed from the plates.



Note:

When first turned on, there may be light smoke emitted. This is due to the heating of internal components and it will pass in a moment.

REPLACING BAKING PLATES

- 1) Before replacing the baking plates disconnect the sandwich maker from the el. power supply and allow it to cool down.
- 2) REMOVING THE BAKING PLATES:
Move locks **C3** towards the handle **A3** to release the bottom baking plate and then remove it. In the same way release and remove the top plate.
- 3) INSERTING THE BAKING PLATES:
Slide the bottom edge of the baking plate under the left and right hinge **C2** and **C4**. Fold the plate down and push in towards the casing of the sandwich maker until you hear an audible click. Now the plate is secured in the correct position by locks **C3**. In the same way attach the top plate. Always use plate of the same type.

USING THE SANDWICH MAKER

- 1) Select a suitable type of plate for the type of food that you wish to prepare and insert it into the sandwich maker, see chapter Replacing baking plates. Coat the baking plates with a little butter or cooking oil.
- 2) Connect the Sandwich Maker to a power supply. Both indicator lights on the top panel will light up. Red indicator light **A2** indicates connection into the electric power supply. Green indicator light **A1** indicates that the baking plates are heating up.
- 3) Close the Sandwich Maker for more effective pre-heating of the baking plates.
- 4) Prepare the food you wish to cook before the plates heat up.
- 5) When the baking plates are heated to the operating temperature, the Green indicator light **A1** is turned off.

EN-7

Sandwich Maker with Removable Plates

SSM 9940SS

Note:

The heating indicator light turns on and off. This shows that the operating temperature of baking plates is maintained.

Open the Sandwich Maker and place the prepared food on the bottom plate. Using the handle **A3** close and press the top baking plate on to the bottom plate. Secure handles **A3** with the lock **A4**.

Note:

If you insert too much food or pieces that are too large into the sandwich maker, then it will not be possible to close it. In such a case it will be necessary to remove some of the food or to cut the food into smaller pieces. Do not force the sandwich maker shut, as this may damage it.

- 6) After 2 to 3 minutes release the lock **A4**, open the top plate and remove the finished meal or continue cooking if necessary. To remove the meal use a wooden or heat-resistant plastic spatula. Do not use a fork, a knife or anything else made of metal. This may damage the non-stick coating.
- 7) Before inserting further food into the sandwich maker close it and wait until the Green indicator light **A1** turns off.
- 8) After you finish using the Sandwich Maker, disconnect the power cord from the el. power supply.

CLEANING AND MAINTENANCE

- Before cleaning the appliance disconnect it from the el. power supply and allow it to cool down.
- Clean the non-stick surface of the baking plates after each use. This will prevent a build-up of burnt pieces of food residue. To clean, use a moist, soft cloth. If some burnt food residue is left on the baking plates, sprinkle with water and mild dish detergent. Wipe clean afterwards with a clean, moist cloth.

Tip:

The baking plates are easier to clean if lukewarm.

- Wipe outer surface of the Sandwich Maker with a soft wet cloth and dry completely off.
- Never rinse the Sandwich Maker under running water or submerge it in water or another liquid.
- Do not use abrasive cleaning products, petrol or solvents for cleaning.

STORAGE

- If the baking plates are cold, close the top plate and secure the handles with the lock. Wind the power cord around the bracket at the bottom of the Sandwich Maker.
- Store the device in a clean, dry place out of reach of children.

Tip:

Storing the Sandwich Maker vertically will save space in your kitchen.

TECHNICAL SPECIFICATIONS

Nominal voltage range.....220-240 V~
 Nominal frequency50/60 Hz
 Rated power input900 W

We reserve the right to change text and technical specifications.

Sandwich Maker with Removable Plates

SSM 9940SS

TIPS FOR PREPARING DELICIOUS SANDWICHES

- For one sandwich you will need two slices of bread and the ingredients to go between them. Place the ingredients neatly between the slices of bread.
- The basic ingredient for the filling can be meat, fish, cheese, smoked meat, sliced cooked egg or fruit and vegetables, like banana, apple, pineapple, tomato, cucumber, onion or mushrooms. Do not use excessive amount of filling, to prevent spilling on the baking plates.
- The filling can be flavoured with spices, herbs, mustard or ketchup.
- To achieve the golden crust colour, the bread can be coated with butter prior to cooking.

Note:

The cooking time for the sandwich depends on the type of bread, the ingredients and your taste.

RECIPES - SANDWICHES

Sandwich with ham, cheese and pineapple (2 pieces)

4 slices of toasting bread
 2 slices of cheese
 4 slices of ham
 2 slices of pineapple

Preheat the baking plates. Between two slices of bread place a slice of cheese, pineapple and two slices of ham. Prepare the second sandwich the same way. It takes 2 to 3 minutes to cook the sandwiches.

Sandwich with tomato and cheese (2 pieces)

4 slices of toasting bread
 1 medium tomato sliced
 2 spoons of grated cheese
 Ground sweet paprika

Preheat the baking plates. Between two slices of bread place a few slices of tomato and sprinkle with grated cheese. Flavour the filling with ground paprika and prepare the second sandwich the same way. It takes 2 to 3 minutes to cook the sandwiches.

Sandwich with chocolate cream and banana (2 pieces)

4 slices of toasting bread
 1/2 of banana sliced thinly
 chocolate cream (peanut butter)

Preheat the baking plates. Lightly spread the chocolate cream on two slices of toasting bread, top with several slices of banana and put together. Prepare the second sandwich the same way. It takes 2 to 3 minutes to cook the sandwiches.

RECIPES - WAFFLES

Waffles

125 g of softened butter
 90 g of sugar
 1 pack of vanilla sugar
 3 eggs
 250 g of fine flour
 1/2 a pack of baking powder
 pinch of salt
 0.5 l of milk
 1 tablespoon of rum

Sandwich Maker with Removable Plates

SSM 9940SS

Spread the butter with the sugar until smooth. Gradually mix in the eggs, flour mixed with a pinch of salt and baking powder, milk and rum. Gently grease the baking plates and allow them to preheat. Pour the resulting dough in part into the bottom baking plate. Bake the dough for approximately 3-5 minutes or until golden brown. Spread jam over the finished waffles and garnish depending on taste with whipped cream and sprinkle with cocoa or chocolate flakes.

Good Appetite

INSTRUCTIONS AND INFORMATION REGARDING THE DISPOSAL OF USED PACKAGING MATERIALS

Dispose of used packaging material at a site designated for waste in your municipality.

DISPOSAL OF USED ELECTRICAL AND ELECTRONIC EQUIPMENT



This symbol on products or original documents means that used electric or electronic products must not be added to ordinary municipal waste. For proper disposal, renewal and recycling hand over these appliances to determined collection points. Alternatively, in some European Union states or other European countries you may return your appliances to the local retailer when buying an equivalent new appliance.

Correct disposal of this product helps save valuable natural resources and prevents potential negative effects on the environment and human health, which could result from improper waste disposal. Ask your local authorities or collection facility for more details.

In accordance with national regulations penalties may be imposed for the incorrect disposal of this type of waste.

For business entities in European Union states

If you want to dispose of electric or electronic appliances, ask your retailer or supplier for the necessary information.

Disposal in other countries outside the European Union.

This symbol is valid in the European Union. If you wish to dispose of this product, request the necessary information about the correct disposal method from the local council or from your retailer.



This product meets all the basic requirements of EU directives related to it.